

**James Walker Moorflex**

# Product Range Manual

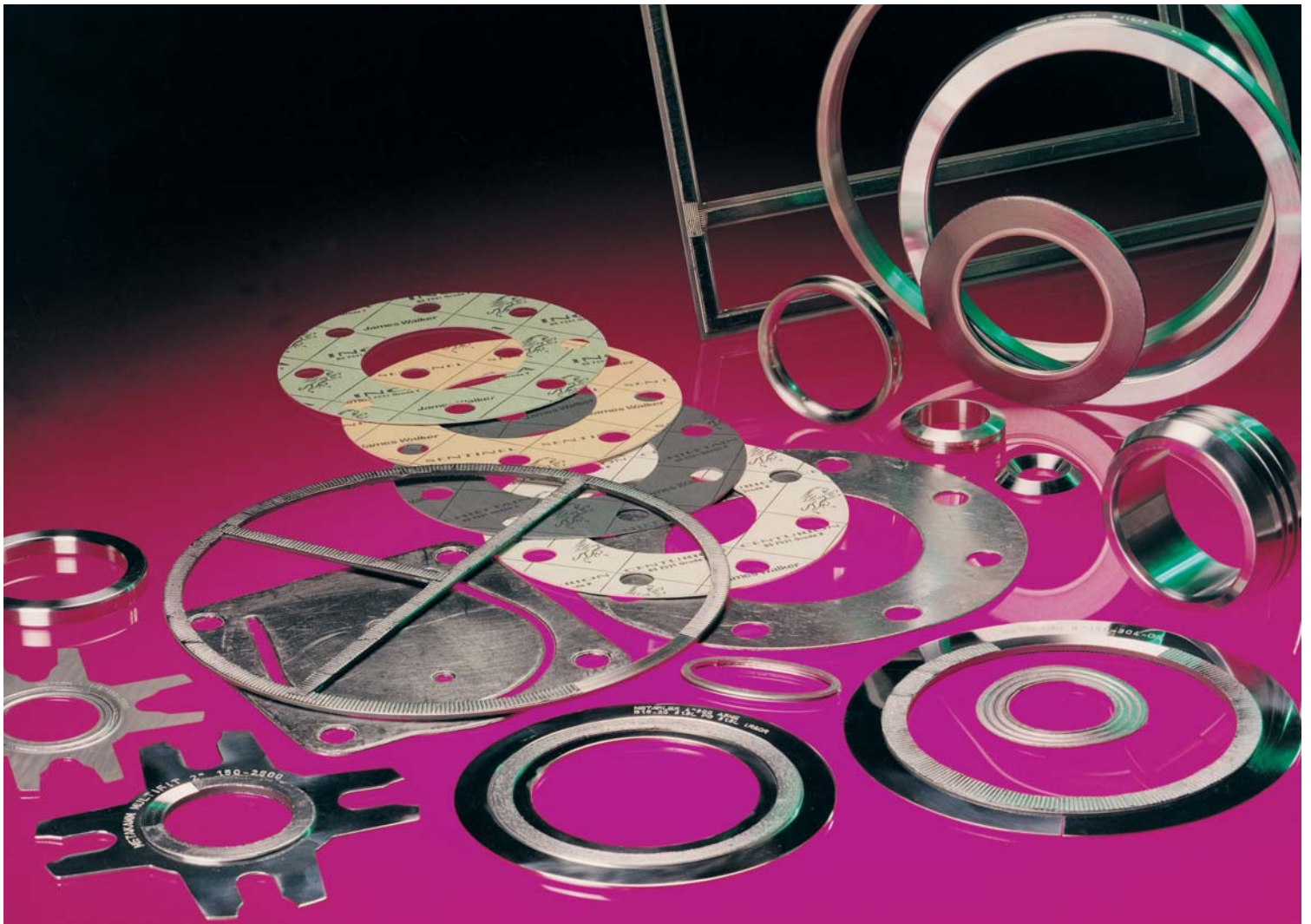

At your service...

**James Walker Moorflex**



## The Company



... over 100 years  
sealing technology  
experience

James Walker Moorflex was created by merging Moorside and James Walker Metaflex - two James Walker Group companies which bring together over 100 years experience at the forefront of sealing technology.

Their mutual commitment to manufacturing excellence, service, research and development, together with their international reputation, ensure that Moorflex is uniquely placed to deliver the best products, backed by the finest service, world-wide.

This commitment is borne out through the most comprehensive stock availability in the gasket industry, a 24 hour emergency breakdown service, plus the strategic location of manufacturing and service facilities throughout the world.

All James Walker Group companies and distributors offer full technical support to their customers.

## Index

### Page

- 2 The Company
- 4 The Product File
- 6 Non-Metallic Gaskets
- 11 Flange Insulation Sets
- 14 Semi-Metallic Gaskets
- 29 Metallic Gaskets



...brand names  
you can trust

In the world of sealing technology, James Walker®, Moorside™ and Metaflex® are three of the most widely known and respected brand names, with an enviable reputation for quality and reliability. For many users they are the first choice for trouble-free operations.





# A world-wide reputation for quality...

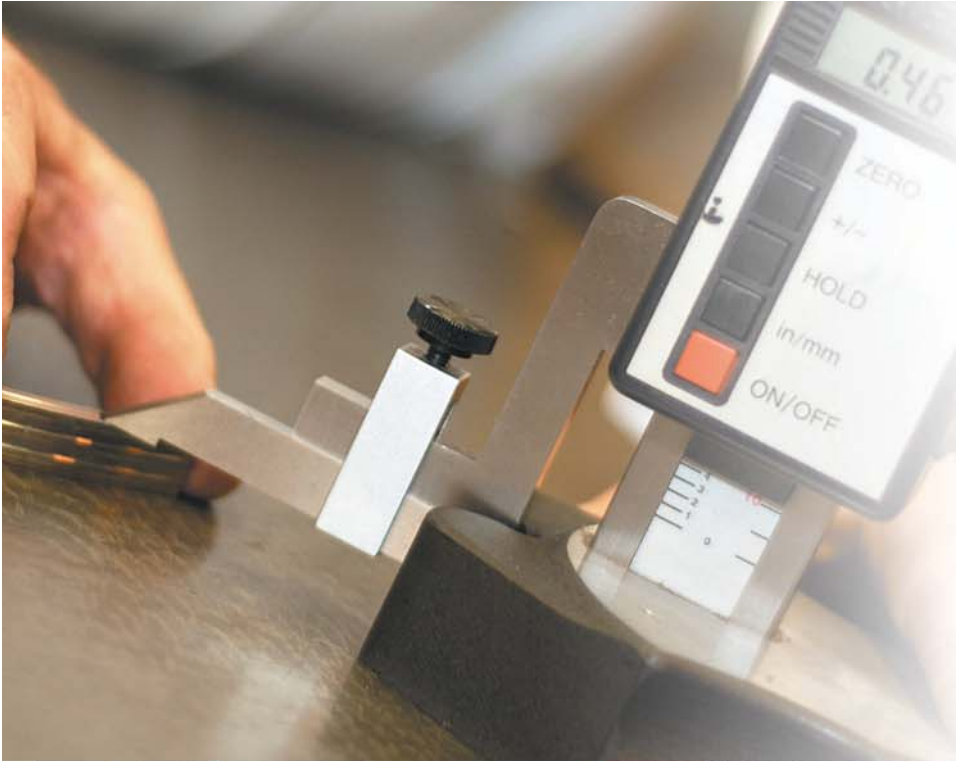

Throughout the world the oil, gas, petroleum and chemical processing industries operate in environments where only the strongest survive.

The precision engineering of materials and their supply, wherever and whenever they are required, is fundamental in order to gain the trust of operators in these most demanding technologies.

Our aim is to supply quality products and services and to fulfil our customers' expectations. This is underpinned by our Quality System approvals to ISO 9001:2000 and API Spec Q1-Standard 6A, which are supplemented by many company and independent authority approvals.

Moorflex takes great pride in having achieved universal acceptance for providing gaskets used in sealing applications where extreme mechanical and thermal performance demands are considered routine.

There are many companies in the sealing industry. Very few can boast the quality of products, quality of service and quality of people found at Moorflex.

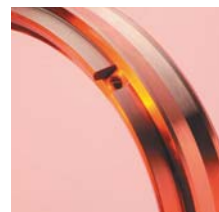

Certificate No. FM 01327  
Certificate No. Q 05429



Licensed Under  
API Spec. 6A-0038



## The Product Profile



### Introduction

James Walker Moorflex gaskets set the standards for sealing technology excellence world-wide. Metal, graphite, PTFE, non-metallic and semi-metallic; the range of gasket materials available is as diverse as the operating environments to which they are subjected. Wherever a pipe or valve is connected there's a Moorflex gasket to ensure the join is safe, strong and totally reliable - from reactors to heat exchangers, pipelines to pressure vessels.

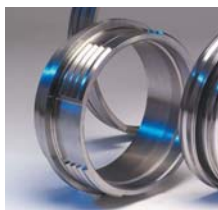

### Support services

In order to provide the best in service and reduce the costs of downtime, Moorflex has established a network of manufacturing and service centres world-wide. This network is continually being reviewed and expanded to meet the constantly rising demands of the energy industries.

Services offered in conjunction with other James Walker Group companies include:

Leak detection and repair.

Tension control fasteners.

On site repair and installation.





**Soft Cut Gaskets**  
Non-metallic gaskets in a wide range of materials (including materials to replace all asbestos products) for standard and non-standard flanges.

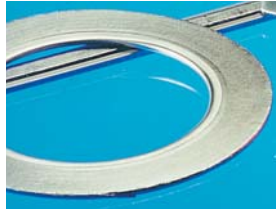

**Eyeletted Gaskets**  
Graphite and non-metallic gaskets fitted with internal and external reinforcements to improve handling and performance.



**Metal Reinforced Graphite**  
These resilient gaskets are manufactured from high purity expanded graphite, reinforced with metallic inserts to ease installation and enhance performance.



**PTFE Gaskets**  
Flat gaskets with a high chemical resistance, supplied either as solid or envelope designs for pipe flanges and vessels.

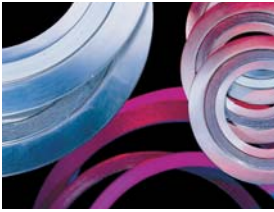

**Spiral Wound Gaskets**  
Metalflex spiral wound gaskets are manufactured from a v-shaped metal strip, spirally wound with an inlay of filler between each turn.  
Spiral wound gaskets are available in both standard and non-standard designs.



**Metal Jacketed Gaskets**  
Widely used in heat exchangers, pressure vessels, valves and pumps, metal jacketed gaskets feature a soft, pliable filler core encased in metal, to offer chemical and thermal resistance in diverse operating conditions.



**Corrugated Gaskets**  
Resilient, metal gaskets suitable for a wide range of flanged connections.



**Grafonic Gaskets**  
Metal gaskets with grooved faces and sealing layers for heat exchangers, vessels, reactors and flanged connections.



**Kammprofile Gaskets**  
Metal gaskets with grooved faces and sealing layers for heat exchangers, vessels, reactors and flanged connections.



**Multiple Pressure Gaskets**  
Semi-metallic gaskets capable of satisfying the complete pressure range of a single nominal bore pipeline - one gasket fits all class ratings.



**Flange Insulation Sets and PTFE Inner Rings for Ring Joint Gaskets**  
Suitable for the electrical isolation of pipelines and plant in cathodic protection systems and/or hazardous areas.



**Solid Metal Gaskets**  
Flat and profiled metallic gaskets are available to meet all international standards and specifications. Special gaskets can also be developed to satisfy individual requirements.



**Ring Joint Gaskets**  
The R, RX and BX series of ring joint gaskets are designed to meet API, ASME, BS and DIN standards. Moorflex are licensed by the American Petroleum Institute to apply the API monogram to gaskets in accordance with API 6A PSL4.



**Machined Gaskets**  
Working in conjunction with our customers, Moorflex has considerable experience in designing and manufacturing gaskets for all applications.



**Custom Designed Gaskets**  
Special designs (and associated components) to meet the requirements of Original Equipment Manufacturers.



**Rubber Coated Ring Joint Gaskets**  
Reusable ring joint type gaskets used in the testing of valves and well head assemblies.  
Rubber coating prevents damage to flanges and groove scuffing.

## Non-Metallic Gaskets

### Introduction

James Walker produce cut gaskets and sheet jointings in a wide range of non-metallic materials. Gaskets are available ready-cut in most common flange sizes (ASME, DIN etc.) and customer parts can be easily produced to your requirements using state-of-the-art CNC water jet cutting equipment.

### Non-Metallic gasket materials

#### Elastomers

Nitrile, neoprene, ethylene-propylene, silicone and fluorocarbon, just to name a few, are among the many grades of elastomer gasket material available from James Walker. There is a wide range of specification grades to internationally recognised industrial and military requirements as well as "commercial" grades for general purpose applications.

#### Cork-Elastomer

The Nebar® range of cork-elastomers is specified by customers world-wide. The Nebar® range is substantial, with grades covering applications from high voltage switchgear to aircraft fuelling equipment.

#### Calendered Fibre

A range of Compressed Non Asbestos Fibre calendered jointing materials (Chieftain®, Centurian®, Sentinel®, and Inca), covers most applications previously served by Compressed Asbestos jointings. The fibres used are typically carbon, glass and aramid or a mixture of these fibres.

The maximum temperature capabilities are, however, slightly reduced compared to asbestos, and the maximum temperature limits reduce with increasing thickness. Therefore care should always be taken to use the thinnest material wherever possible.

#### PTFE -

Fluolion® Integra White, and Fluolion® Integra Blue, are biaxially-orientated, filled PTFE materials. These are PTFE materials having improved creep resistance to ensure greater reliability in service. They display outstanding chemical resistance, and the Integra Blue grade has increased softness and conformability for use on glass lined flanges or flanges having low bolt-load capacity.

#### Expanded Graphite

Supagraf® is available in a variety of grades, from plain un-reinforced sheet to nickel and stainless steel foil grades, as well as 'T10', which has a tanged stainless steel reinforcing layer, giving superior physical strength and crush resistance.

#### Features

- Excellent chemical resistance.
- Exceptionally wide temperature range: from up to 400°C in oxidising environments and under certain circumstances, to 2500°C in inert conditions.
- Excellent resistance to stress relaxation, even at elevated temperatures.
- High levels of joint stability.
- Outstanding sealing integrity over extended periods.
- Accommodates flange distortions where traditional sheet jointings fail to seal.
- Fire safe.
- Exceptionally low leachable chloride content to resist corrosion.
- Totally compatible with steam, air and water.
- Recommended for use with heat transfer fluids and demineralised water.

## Cut gaskets and services

The Cut Gasket service is dedicated to meeting industry's immediate needs for precision gaskets produced from sheet jointing materials.

Moorflex holds stocks of gaskets to suit flange profiles found in all sectors of industry.

### Emergency Manufacture

In the unlikely event of not having particular gaskets available immediately from stock, James Walker can readily manufacture them, using highly accurate CAD/CAM controlled water-jet cutters. These machines are pre-programmed with every gasket design to national and international standards. Large stocks of non-asbestos sheet jointings, rubber and Supagraf® products in all standard thicknesses are always available.

This same technology enables any shape, size or quantity of non-standard cut gaskets to be produced to the highest precision standards, working from customers' CAD/CAM files sent on disk, C.D. or e-mail. Additionally, profiles can be digitised from drawings, samples or templates, with no need for tooling.

James Walker's state-of-the-art water-jet cutters operate with all major CAD languages. Nesting pattern software, combined with video acquisition equipment to capture the shape of a sheet, ensures the maximum number of gaskets is produced with the minimum material wastage.

These systems are proven to be highly economical for prototype cutting as well as for large batch runs. For metallic materials, such as Supagraf® Tanged Jointing T10, an abrasive water-jet cutter is utilised. This ensures a clean cut and eliminates the hazardous sharp edges which can occur when using conventional press cutting methods.

## Chieftain®

DESCRIPTION	Premium grade universal sheet jointing. Contains an advanced carbon fibre material and a nitrile rubber (NBR) binder. Anti-stick finish to both surfaces is supplied as standard
PRIME FEATURES	Carbon fibre for strength and stability 450°C maximum temperature  Outstanding chemical and steam resistance - User friendly – easy to cut, handle and remove from flanges
SPECIFICATION	Easily meets the requirements of BS7531 Grade X  Suitable for ASME Class 300 flange ratings to at least 260°C



## Centurion®

DESCRIPTION	A high performance sheet jointing based on glass and aramid fibres with a nitrile rubber (NBR) binder. An anti-stick finish to both surfaces is supplied as standard
PRIME FEATURES	Well proven on industrial plants worldwide - Recommended for most fluid media  Chemically and thermally stable for duties up to 440°C - Non-pigmented
SPECIFICATION	Meets the requirements of BS7531 Grade X

## Sentinel®

DESCRIPTION	General-purpose sheet jointing. Comprises compressed aramid fibres with nitrile rubber (NBR) binder. An anti-stick finish to both surfaces is supplied as standard
PRIME FEATURES	Replaces CAF for most industrial duties - Offers outstanding performance for its class  Suitable for a wide range of media
SPECIFICATION	Exceeds the property requirements of BS7531 Grade Y. WRAS approved for use with hot + cold potable water up to 85° C

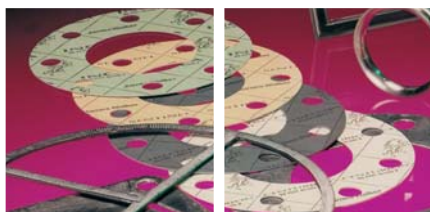

## Inca

DESCRIPTION	A high quality, reliable, economically priced jointing based on glass and aramid fibres combined with a nitrile (NBR) binder. Anti-stick finish to both surfaces is supplied as standard
PRIME FEATURES	A durable jointing for general purpose, medium performance, duties  Suitable for steam, condensate, water, oils, solvents and a wide range of other media  Value engineered to provide excellent value for money
SPECIFICATION	Readily meets the property requirements of BS7531 Grade Y. WRAS approved for use with hot + cold potable water up to 85° C

## Fluolion® INTEGRA BLUE

DESCRIPTION	General purpose PTFE-based sheet jointing specially stabilised & mechanically treated to improve multi-directional strength, combat creep & improve resilience for flange jointing duties.
TYPICAL APPLICATIONS	Flanged joints on plant that handles aggressive fluid media, especially where hygiene is top priority – such as in the pharmaceutical, food & electronic industries. Especially suited to applications with weak or lightly loaded flanges, as well as standard flange duties.
PRIME FEATURES	Highly recommended for duties with caustic alkalis and strong acids, at elevated temperatures and moderate concentrations - Can be used at cryogenic temperatures  High compressibility for effective sealing on lightly loaded flanges  Inherently clean, non-toxic and non-tainting  Outstanding resistance to a very wide range of chemical media
SPECIFICATION	Complies with requirements FDA Regs for food use  WRAS approved for use with hot & cold potable water up to 85°C



## Fluolion® INTEGRA WHITE

DESCRIPTION	Specially stabilised PTFE sheet material, mechanically treated to improve multi-directional strength, combat creep and improve resilience for flange jointing duties.
TYPICAL APPLICATIONS	Flanged joints on plant that handles extremely aggressive fluid media. Also where hygiene is top priority – such as in the pharmaceutical, food & electronic industries
PRIME FEATURES	<p>Highly recommended for duties with strong acids &amp; oxidising agents at elevated temperatures &amp; all concentrations</p> <p>Outstanding resistance to a very wide range of chemical media</p> <p>Inherently clean, non-toxic and non-tainting</p> <p>Can be used at cryogenic temperatures</p> <p>Displays compressibility and recovery characteristics close to those of many non-asbestos fibre jointings</p>
SPECIFICATION	<p>Complies with requirements of FDA Regulations for food use, and USP 25, Class V, classification of plastics for pharmaceutical service</p> <p>WBS approved for use with hot and cold potable water up to 85° C</p>

## Supagraf® PLAIN JOINTING

DESCRIPTION	Sheet jointing of 98% pure exfoliated graphite. An Ultra High Purity (99.8%) grade is available for nuclear industry applications
PRIME FEATURES	<p>Widest temperature range</p> <p>Potable water duties &amp; repeated use with foodstuffs</p> <p>Very easy to cut – but large gaskets may need support during carriage &amp; fitting</p>
SPECIFICATION	WBS approved for use with hot & cold potable water up to 85° C

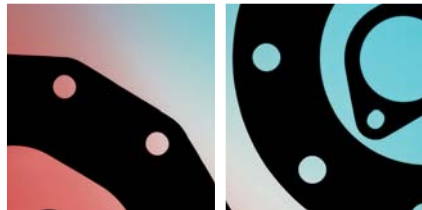

## Supagraf® TANGED JOINTING T10

DESCRIPTION	Sheet jointing of 98% pure exfoliated graphite reinforced with a central layer of 0.1mm thick tanged stainless steel. The graphite is compressed onto the perforated metal sheet to give a secure mechanical lock without adhesive
PRIME FEATURES	<p>Exceptional resistance to blow-out &amp; crushing</p> <p>Anti-stick coating available</p> <p>Extra strength for ease of handling &amp; fitting</p>
SPECIFICATION	BAM approved for use with liquid and gaseous oxygen in flange connections of copper, copper alloys or steel at operating conditions up to 130bar & 200°C

## Supagraf® LAMINATED JOINTING S 10

DESCRIPTION	Sheet jointing of 98% pure exfoliated graphite with a bonded central layer of 50µm thick stainless steel foil. Sheets thicker than 2mm have two layers of metal foil and three of graphite
PRIME FEATURES	<p>Extra strength for ease of handling &amp; fitting</p> <p>Excellent sealing integrity</p> <p>Can be cut with hand tools</p>
SPECIFICATION	S10 Grade is BAM approved for use with liquid and gaseous oxygen in flange connections of copper, copper alloys or steel at operating conditions up to 130bar & 200°C

## Supagraf® LAMINATED JOINTING N7

DESCRIPTION	This material has all the attributes of Supagraf® Laminated Jointing S10, as described left, with the following important exceptions:
PRIME FEATURES	<p>Contains layer/s of nickel foil instead of stainless steel</p> <p>Extra strength for ease of handling &amp; fitting</p> <p>Excellent sealing integrity</p> <p>Can be cut with hand tools</p>



# Sheet jointings

## Chemical suitability guide

SHEET JOINTINGS	Cheftain®	Centurian®	Sentinel®	Inca	Fluolion® INTEGRA BLUE	Fluolion® INTEGRA WHITE
STEAM	1	1	1	1	1	1
STEAM CONDENSATE	1	1	1	1	1	1
WATER	1	1	1	1	1	1
AIR	1	1	1	1	1	1
ACETIC ACID	1	1	50%	50%	1	1
ACETONE	1	1	1	1	1	1
ACETYLENE	1	1	1	1	1	1
ADIPIC ACID	1	1	1	1	1	1
ALUMINIUM CHLORIDE	1	1	NO	1	1	1
AMMONIA (Anhydrous, dry)	1	1	1	1	1	1
AMMONIA (wet)	1	1	NO	1	1	1
AMMONIUM CHLORIDE	1	1	NO	1	1	1
AMMONIUM HYDROXIDE	1	1	10%	1	1	1
ANILINE	1	1	1	1	1	1
BENZENE	1	1	1	1	1	1
BITUMEN & HEAVY BOTTOMS	1	1	1	1	1	1
BLACK LIQUOR	1	1	NO	1	30°C	NO
BLEACH SOLUTIONS	1	1	NO	NO	1	1
BOILER FEED WATER	1	1	1	1	1	1
BRINE	1	1	1	1	1	1
BROMINE	NO	NO	NO	NO	1	1
BUNKER FUEL	1	1	1	1	1	1
BUTANE	1	1	1	1	1	1
CALCIUM CHLORIDE	1	1	1	1	1	1
CALCIUM HYDROXIDE	1	1	1	1	1	NO
CALCIUM HYPOCHLORITE	1	1	NO	NO	1	1
CARBON DIOXIDE	1	1	1	1	1	1
CARBON DISULPHIDE	NO	NO	NO	NO	1	1
CARBON TETRACHLORIDE	1	1	NO	NO	1	1
CHLORINE (dry)	1	1	1	1	1	1
CHLORINE (wet)	1	NO	NO	NO	1	1
CHROMIC ACID	NO	NO	NO	NO	NO	1
CREOSOTE	1	1	1	1	1	1
DIESEL OIL	1	1	1	1	1	1
DIETHYL ETHER	1	1	1	1	1	1
DOWTHERM®	1	1	NO	NO	1	1
ETHANE	1	1	1	1	1	1
ETHANOLAMINES	1	1	1	1	1	1
ETHER	1	1	1	1	1	1
ETHYL ALCOHOL (Ethanol)	1	1	1	1	1	1
ETHYLAMINE	1	1	1	1	1	1
ETHYLENE	1	1	1	1	1	1
ETHYLENE GLYCOL	1	1	NO	1	1	1
ETHYLENE OXIDE	1	1	NO	NO	1	1
FERRIC CHLORIDE (wet)	NO	NO	NO	NO	1	1
FLUORINE	NO	NO	NO	NO	NO	NO
FORMALDEHYDE	1	1	1	1	1	1
FORMIC ACID	1	1	50%	10%	1	1
GASOLINE	1	1	1	1	1	1
GREEN LIQUOR	1	1	NO	NO	30°C	NO
HEAVY OILS	1	1	1	1	1	1
HYDROBROMIC ACID	NO	NO	NO	NO	NO	1
HYDROCHLORIC ACID	NO	NO	NO	NO	NO	1
HYDROFLUORIC ACID	NO	NO	NO	NO	NO	NO
HYDROGEN CHLORIDE GAS (dry)	1	1	NO	NO	1	1
HYDROGEN PEROXIDE (< 30%)	1	1	1	1	1	1
HYDROGEN SULPHIDE	1	1	NO	1	1	1
ISOPROPYL ALCOHOL	1	1	1	1	1	1
KEROSENE	1	1	1	1	1	1

SHEET JOINTINGS	Cheftain®	Centurian®	Sentinel®	Inca	Fluolion® INTEGRA BLUE	Fluolion® INTEGRA WHITE
LINSEED OIL	1	1	1	1	1	1
LIQUID PETROLEUM GAS	1	1	1	1	1	1
LYE	1	1	NO	1	30°C	NO
METHANE	1	1	1	1	1	1
METHYL ALCOHOL (Methanol)	1	1	1	1	1	1
METHYL CHLORIDE	1	1	1	1	1	1
METHYL ETHYL KETONE	1	1	1	1	1	1
METHYL TERTIARY BUTYL ETHER	1	1	1	1	1	1
METHYLATED SPIRITS	1	1	1	1	1	1
METHYLENE CHLORIDE	1	NO	NO	NO	1	1
MINERAL OILS	1	1	1	1	1	1
NAPHTHA	1	1	1	1	1	1
NATURAL GAS	1	1	1	1	1	1
NITRIC ACID	NO	NO	NO	NO	NO	1
NITROGEN	1	1	1	1	1	1
OCTANE	1	1	1	1	1	1
OLEUM	NO	NO	NO	NO	NO	1
OXALIC ACID	1	1	NO	50%	1	1
OXYGEN	NO	NO	NO	NO	NO	NO
PERCHLOROETHYLENE	1	1	1	1	1	1
PHENOLS	1	1	NO	NO	1	1
PHOSPHORIC ACID (50%)	1	1	NO	10%	1	1
POTASSIUM DICHROMATE (10%)	1	1	1	1	1	1
POTASSIUM HYDROXIDE (50%)	70°C	70°C	NO	NO	100%	NO
PROPANE	1	1	1	1	1	1
PYRIDINE	1	1	NO	NO	1	1
RAPE SEED OIL	1	1	1	1	1	1
REFRIGERANT R12 (eg Freon® 12)	1	1	1	1	1	1
R22 (eg Freon® 22)	1	1	NO	NO	1	1
R134a (eg KLEA® 134a)	1	1	1	1	1	1
R404a (eg KLEA® 404a)	1	1	1	1	1	1
R407 (eg KLEA® 407series)	1	1	1	1	1	1
SEA WATER	1	1	1	1	1	1
SODA ASH	1	1	1	1	1	1
SODIUM CARBONATE	1	1	1	1	1	1
SODIUM DICHROMATE (10%)	1	1	1	1	1	1
SODIUM HYDROXIDE (50%)	70°C	70°C	NO	NO	100%	NO
SODIUM HYPOCHLORITE	NO	1	NO	NO	1	1
STARCH	1	1	1	1	1	1
STYRENE	1	1	1	1	1	1
SULPHUR DIOXIDE (dry)	1	1	NO	NO	1	1
SULPHUR DIOXIDE (wet)	NO	NO	NO	NO	1	1
SULPHUR TRIOXIDE	NO	NO	NO	NO	1	1
SULPHURIC ACID	NO	NO	NO	NO	NO	1
TANNIC ACID	1	1	1	NO	1	1
TITANIUM DIOXIDE	1	1	1	1	1	1
TITANIUM TETRACHLORIDE	1	1	NO	NO	1	1
TOLUENE (Toluol)	1	1	1	1	1	1
TRANSFORMER OIL	1	NO	NO	NO	1	1
TRICHLOROETHANE	1	1	NO	NO	1	NO
TRICHLOROETHYLENE	1	1	1	1	1	1
TURPENTINE	1	1	1	1	1	1
UREA	1	1	1	1	1	1
VINYL ACETATE	1	1	1	1	1	1
VINYL CHLORIDE	1	1	1	1	1	1
WHITE LIQUOR	1	1	NO	NO	30°C	NO
WHITE SPIRIT	1	1	1	1	1	1
XYLENE	1	1	1	1	1	1

### Notation:

- Suitable product

Where chemical compatibility is not indicated, or a chemical is not listed, please consult our technical services team for a recommendation to be made.

Due to the complexity of making a recommendation for any given duty, this section on chemical suitability is intended only as a guide. The possible effect of elevated temperatures should be considered when determining the compatibility of these products with a chemical. If necessary, please contact our technical services team for assistance.

Dowtherm® is a registered trademark of Dow Chemical Company Limited. Freon® is a registered trademark of ElDuPont de Nemours & Company. KLEA® is a registered trademark of ICI C & P Ltd.

# Supagraf® products

## Chemical suitability guide

Supagraf® PRODUCTS	Supagraf® PLAIN & HIGH PURITY	Supagraf® TANGED T10	Supagraf® LAMINATED N7	Supagraf® LAMINATED S10
STEAM	1	1	1	1
STEAM CONDENSATE	1	1	1	1
WATER	1	1	1	1
AIR	1	1	1	1
ACETIC ACID	1	NO	1	NO
ACETONE	1	1	1	1
ACETYLENE	1	1	1	1
ADIPIC ACID	1	1	NO	1
ALUMINIUM CHLORIDE	1	1	NO	1
AMMONIA (Anhydrous, dry)	1	1	1	1
AMMONIA (wet)	1	1	1	1
AMMONIUM CHLORIDE	1	1	1	1
AMMONIUM HYDROXIDE	1	NO	NO	NO
ANILINE	1	1	1	1
BENZENE	1	1	1	1
BITUMEN & HEAVY BOTTOMS	1	1	1	1
BLACK LIQUOR	1	1	NO	1
BLEACH SOLUTIONS	NO	NO	NO	NO
BOILER FEED WATER	1	1	1	1
BRINE	1	NO	NO	NO
BROMINE	NO	NO	NO	NO
BUNKER FUEL	1	1	1	1
BUTANE	1	1	1	1
CALCIUM CHLORIDE	1	1	1	1
CALCIUM HYDROXIDE	1	1	1	1
CALCIUM HYPOCHLORITE	30%	30%	30%	30%
CARBON DIOXIDE	1	1	1	1
CARBON DISULPHIDE	1	1	NO	1
CARBON TETRACHLORIDE	1	1	1	1
CHLORINE (dry)	20°C	20°C	20°C	20°C
CHLORINE (wet)	NO	NO	NO	NO
CHROMIC ACID	NO	NO	NO	NO
CREOSOTE	1	1	1	1
DIESEL OIL	1	1	1	1
DIETHYL ETHER	1	1	1	1
DOWTHERM®	1	1	1	1
ETHANE	1	1	1	1
ETHANOLAMINES	1	1	1	1
ETHER	1	1	1	1
ETHYL ALCOHOL (Ethanol)	1	1	1	1
ETHYLAMINE	1	1	1	1
ETHYLENE	1	1	1	1
ETHYLENE GLYCOL	1	1	1	1
ETHYLENE OXIDE	1	1	1	1
FERRIC CHLORIDE (wet)	1	1	NO	1
FLUORINE	NO	NO	NO	NO
FORMALDEHYDE	1	1	1	1
FORMIC ACID	1	1	1	1
GASOLINE	1	1	1	1
GREEN LIQUOR	NO	NO	NO	NO
HEAVY OILS	1	1	1	1
HYDROBROMIC ACID	37%	NO	NO	NO
HYDROCHLORIC ACID	1	NO	NO	NO
HYDROFLUORIC ACID	1	NO	NO	NO
HYDROGEN CHLORIDE GAS (dry)	1	1	1	1
HYDROGEN PEROXIDE (< 30%)	1	1	1	1
HYDROGEN SULPHIDE	1	1	1	1
ISOPROPYL ALCOHOL	1	1	1	1
KEROSENE	1	1	1	1

Supagraf® PRODUCTS	Supagraf® PLAIN & HIGH PURITY	Supagraf® TANGED T10	Supagraf® LAMINATED N7	Supagraf® LAMINATED S10
LINSEED OIL	1	1	1	1
LIQUID PETROLEUM GAS	1	1	1	1
LYE	1	1	1	1
METHANE	1	1	1	1
METHYL ALCOHOL (Methanol)	1	1	1	1
METHYL CHLORIDE	1	1	1	1
METHYL ETHYL KETONE	1	1	1	1
METHYL TERTIARY BUTYL ETHER	1	1	1	1
METHYLATED SPIRITS	1	1	1	1
METHYLENE CHLORIDE	1	1	1	1
MINERAL OILS	1	1	1	1
NAPHTHA	1	1	1	1
NATURAL GAS	1	1	1	1
NITRIC ACID (50%)	40°C	NO	NO	NO
NITROGEN	1	1	1	1
OCTANE	1	1	1	1
OLEUM	NO	NO	NO	NO
OXALIC ACID	1	1	1	1
OXYGEN	NO	1	NO	1
PERCHLOROETHYLENE	1	1	1	1
PHENOLS	1	1	1	1
PHOSPHORIC ACID (85%)	1	60°C	20°C	60°C
POTASSIUM DICHROMATE (10%)	1	1	1	1
POTASSIUM HYDROXIDE (50%)	1	1	1	1
PROPANE	1	1	1	1
PYRIDINE	1	1	1	1
RAPE SEED OIL	1	1	1	1
REFRIGERANT R12 (eg Freon® 12)	1	1	1	1
R22 (eg Freon® 22)	1	1	1	1
R134a (eg KLEA® 134a)	1	1	1	1
R404a (eg KLEA® 404a)	1	1	1	1
R407 series (eg KLEA® 407series)	1	1	1	1
SEA WATER	1	20°C	20°C	20°C
SODA ASH	1	1	1	1
SODIUM CARBONATE	1	1	1	1
SODIUM DICHROMATE (10%)	1	1	1	1
SODIUM HYDROXIDE (50%)	1	1	1	1
SODIUM HYPOCHLORITE (25%)	1	NO	20°C	NO
STARCH	1	1	1	1
STYRENE	1	1	1	1
SULPHUR DIOXIDE (dry)	1	1	1	1
SULPHUR DIOXIDE (wet)	1	1	1	1
SULPHUR TRIOXIDE	NO	NO	NO	NO
SULPHURIC ACID	70%	70%	50%	70%
TANNIC ACID	1	1	1	1
TITANIUM DIOXIDE	1	1	1	1
TITANIUM TETRACHLORIDE	1	1	1	1
TOLUENE (Toluol)	1	1	1	1
TRANSFORMER OIL	1	1	1	1
TRICHLOROETHANE	1	1	1	1
TRICHLOROETHYLENE	1	1	1	1
TURPENTINE	1	1	1	1
UREA	1	1	1	1
VINYL ACETATE	1	1	1	1
VINYL CHLORIDE	1	1	1	1
WHITE LIQUOR	NO	NO	NO	NO
WHITE SPIRIT	1	1	1	1
XYLENE	1	1	1	1

### Notation:

- Suitable product

Where chemical compatibility is not indicated, or a chemical is not listed, please consult our technical services team for a recommendation to be made.

Due to the complexity of making a recommendation for any given duty, this section on chemical suitability is intended only as a guide. The possible effect of elevated temperatures should be considered when determining the compatibility of these products with a chemical. If necessary, please contact our technical services team for assistance.

Dowtherm® is a registered trademark of Dow Chemical Company Limited. Freon® is a registered trademark of ElDuPont de Nemours & Company. KLEA® is a registered trademark of ICI C & P Ltd.



# Flange Insulation Sets



## Introduction

James Walker Moorflex flange insulation sets are installed worldwide in numerous pipeline systems, where they perform an essential role in the isolation of the flow of electrical current. Moorflex have considerable experience in the manufacture and utilisation of flange insulation components and are committed to providing our customers with cost effective and efficient solutions.

For quality products and superb service, industry puts its trust in Moorflex.

## Typical applications

In order to ensure efficient operation of cathodic protection systems for stainless steel pipelines, it is necessary to divide the pipelines into manageable lengths. The installation of flange insulation sets at each flanged joint ensures effective sealing and isolation.

The transfer of volatile fluids through pipeline systems may result in explosive conditions, which could be ignited by stray electrical currents, either from cathodic protection systems or the phenomenon known as 'eddy currents'. This potentially disastrous situation can be minimised or eliminated through the installation of appropriate flange insulation sets at strategic points.

Contact between dissimilar metals will result in accelerated corrosion of the weaker material due to galvanic corrosion. This contact normally takes place between flanges, and can be eliminated by the installation of suitable flange insulation sets.





# Design concept & gasket styles

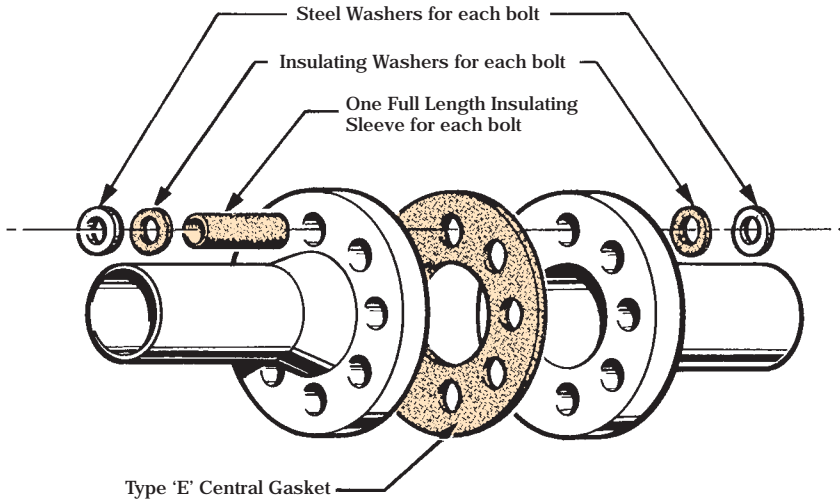

It is essential that such a flange insulation set arrangement has the following design criteria applied to achieve the optimum results:

- The electrical resistance properties of the components are balanced for the purpose and location in the insulation system.
- The components are manufactured from insulating materials with high compressive strength and good stability. Under no circumstances should materials which express cold flow properties be used, as relaxation may occur after bolt tightening is completed. This will result in a reduction in the load applied to the gasket and leakage will take place.

Flange insulation sets comprise the following components which ensure that full electrical isolation is achieved.

- 1 - Central insulating gasket which is fitted between the flanges.
- 1 - Insulating sleeve per flange bolt.
- 2 - Insulating washers per flange bolt.
- 2 - Metal backup washers per flange bolt.

Note: The efficiency of the components may be enhanced by over-wrapping the gap between the flange faces with heavy duty insulating tape.

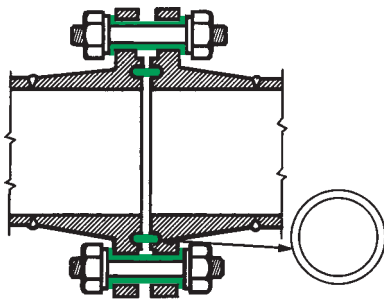

## TYPE D SETS

Utilising an oval section gasket manufactured from a suitable insulating material, Type D Sets fit into a standard RTJ flange ring groove.

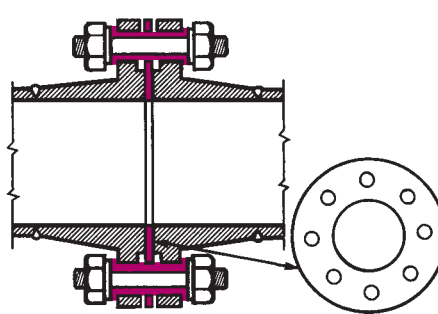

## TYPE E SETS

This style is suitable for raised face and flat flanges. The use of a full face gasket reduces the risk of electrical bridging and the ingress of foreign matter between the flanges.

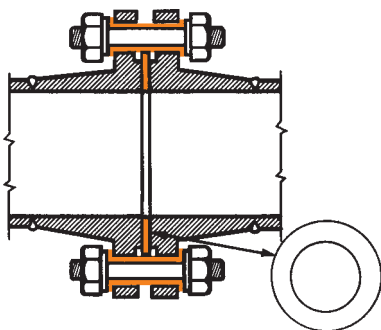

## TYPE F SETS

These sets are suitable for raised face flanges, and use a central gasket which locates inside the bolt circle of the flange. Whilst not being as efficient as Type E sets, they have the advantage of allowing fitting without complete separation of the flange, and may be regarded as "drop in" gaskets.

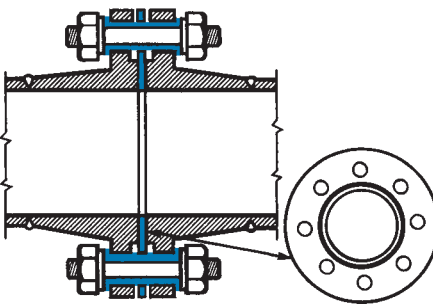

## TYPE G SETS

This style is available in both full face and inside bolt circle versions and incorporates an elastomeric sealing ring in the gasket faces. Appropriate selection of insulating and sealing materials provides a versatile set with higher chemical and temperature resistance.



# Material selection

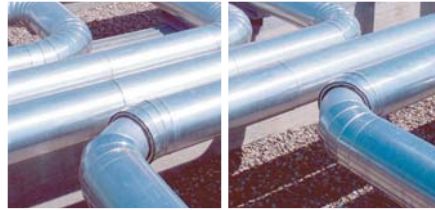

## How to order

- 1 Quantity
- 2 Nominal bore and flange specification
- 3 Style from table, eg **E**, **F**, **D**, **G**
- 4 Materials

### CENTRAL GASKET

- NEOPRENE FACED PAPER REINFORCED PHENOLIC
- PLAIN COTTON REINFORCED PHENOLIC
- HIGH DIELECTRIC STRENGTH CNAF
- COTTON REINFORCED PHENOLIC WITH NITRILE SEALS
- GLASS REINFORCED EPOXY WITH VITON SEALS
- PLASTIC COATED SOFT IRON

### INSULATION SLEEVES

- REINFORCED PHENOLIC
- SPIRALLY WOUND POLYESTER MYLAR
- SPIRALLY WOUND NOMEX

### INSULATION WASHERS

- COTTON REINFORCED PHENOLIC
- GLASS REINFORCED PHENOLIC
- GLASS REINFORCED EPOXY

### STEEL BACK UP WASHERS

- CARBON STEEL ZINC PLATED
- STAINLESS STEEL AISI 316

	<b>E</b>	<b>F</b>	<b>D</b>	<b>G</b>	<b>MAX TEMP °C</b>	<b>DIELECTRIC STRENGTH VOLTS/MIL</b>	<b>WATER ABSORPTION %</b>	<b>COMPRESSIVE STRENGTH N/mm<sup>2</sup></b>
NEOPRENE FACED PAPER REINFORCED PHENOLIC	●	●			100	500	0.6	168
PLAIN COTTON REINFORCED PHENOLIC	●	●	●		115	200	0.5	300
HIGH DIELECTRIC STRENGTH CNAF	●	●			400	350	5	-
COTTON REINFORCED PHENOLIC WITH NITRILE SEALS				●	115	200	0.6	300
GLASS REINFORCED EPOXY WITH VITON SEALS				●	155	500	0.1	400
PLASTIC COATED SOFT IRON			●		-	-	-	-
REINFORCED PHENOLIC	●	●	●	●	80	200	0.6	N/A
SPIRALLY WOUND POLYESTER MYLAR	●	●	●	●	120	700	0.5	N/A
SPIRALLY WOUND NOMEX	●	●	●	●	220	-	-	N/A
COTTON REINFORCED PHENOLIC	●	●	●	●	115	200	0.5	300
GLASS REINFORCED PHENOLIC	●	●	●	●	140	175	0.4	400
GLASS REINFORCED EPOXY	●	●	●	●	155	500	0.1	400
CARBON STEEL ZINC PLATED	●	●	●	●	N/A	N/A	N/A	N/A
STAINLESS STEEL AISI 316	●	●	●	●	N/A	N/A	N/A	N/A

Note: Maximum temperature and pressure guides should not be used simultaneously, contact James Walker Moorflex for advice.

This information is intended as a general guide only and is based upon testing of insulation components, not virgin materials. Material data sheets and recommendations available on request. Additional materials are available for extreme applications.





# Semi-Metallic Gaskets

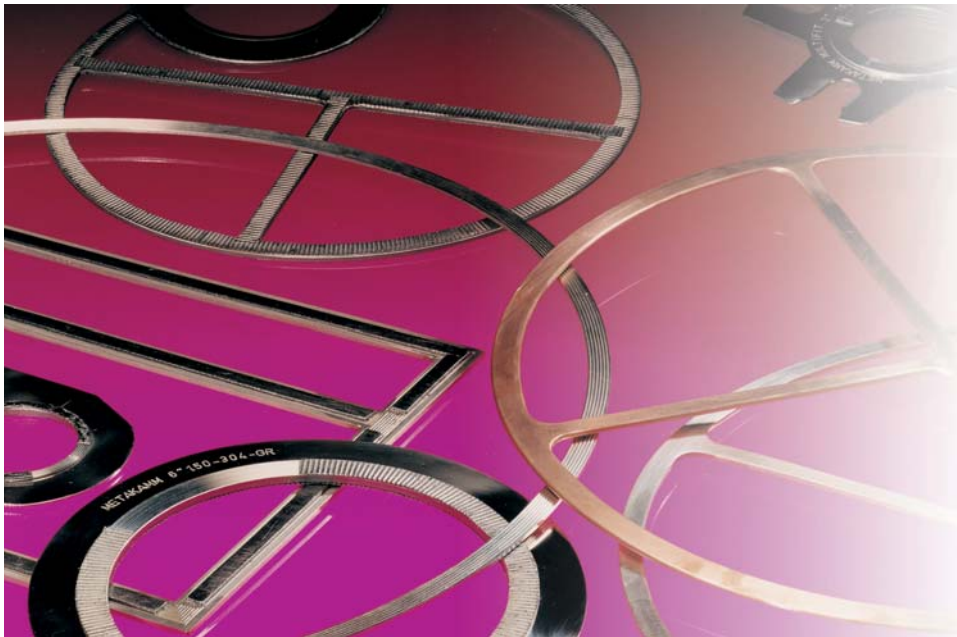

## Introduction

Semi-metallic gaskets are widely used on the following services:

### Steam

- boiler handhole, tubecap and manhole assemblies
- steam and feed water pipe flanges
- feed water heaters
- valve bonnets
- autoclaves

### Petro-chemicals

- catalytic cracking plant
- vessel closures
- platformers
- line flanges
- heat exchangers
- valve bodies

### Marine

- boilers
- de-aerators
- economisers
- main feed pumps
- main steam lines
- LP and HP feed
- air ejectors
- water heaters
- diesel engines

### Nuclear

- cooling circuit flanges (helium and carbon dioxide)
- high temperature gas lines
- pressure vessels
- valves

### Hydraulic

- high pressure line flanges
- pump and valve bodies

## Flange standards

Gaskets can be manufactured in accordance with all relevant gaskets standards to suit the following flange designations:



ASME B16.5

BS 1560

BS 10

ASME B16.47 SERIES B (API 605)

ASME B16.47 SERIES A (MSS-SP 44)

BSEN 1092 (BS 4504)

DIN FLANGES

JIS FLANGES

FRENCH NF STANDARD

N.B. Gaskets for non standard flanges are also readily available



# Semi-Metallic gasket types

Metaflex®  
Spiral Wound  
Gaskets

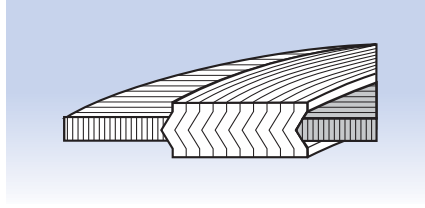

Metakamm®  
Kammprofile  
Gaskets

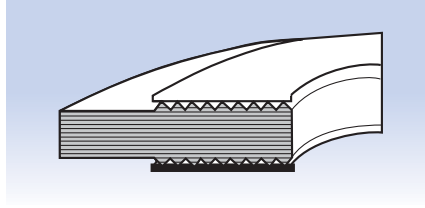

Metal Jacketed  
Gaskets

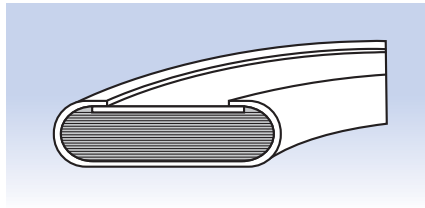

Expanded Graphite  
Gaskets  
Plain or reinforced

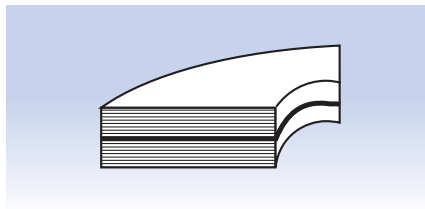

Eyeletted  
Gaskets  
Graphite & compressed fibre

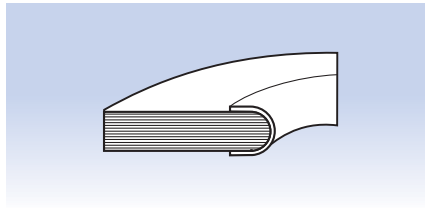

Metcom  
Multi-pressure  
Gaskets

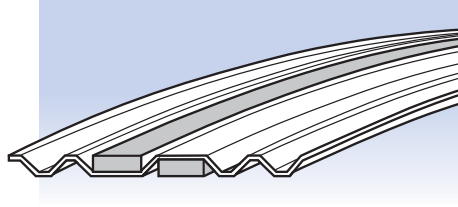

Metagraf

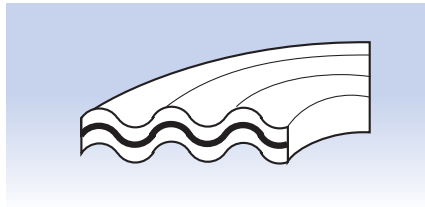

Metex

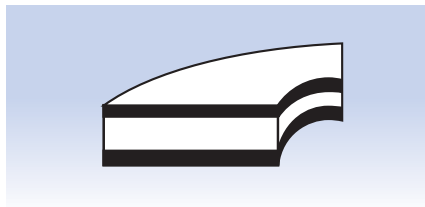

# Metaflex®

## Spiral wound gaskets

Metaflex® gaskets are manufactured from V-shaped metal strips, spirally wound with an inlay of filler between each turn. At the start and conclusion of the spiral form, several continuous turns of the metallic windings are securely welded together.

The construction is capable of infinite variety as the number of metal plies in relation to filler plies can be increased or decreased. The metal and filler material can be varied to suit practically any service conditions.

The use of steel supporting rings on the inside or outside of the spiral wound portion (or both) permits the application of Metaflex® gaskets to be extended to flat or raised face flanges under high pressure lines.

### Features

- Available in materials capable of withstanding temperatures from the cryogenic range to at least 1000°C.
- Can, in standard form, seal pressures up to 350 bar. Higher pressures can be considered on request.
- Maintain a seal under conditions of thermal cycling or vibration.
- Resist corrosion and leave flange faces clean.
- Do not require ground or lapped flange faces.
- Are quick to fit and remove.
- Can often be used on bowed or pitted flanges.
- Offer good performance on difficult dry gas or high vacuum applications.



### Gasket profiles

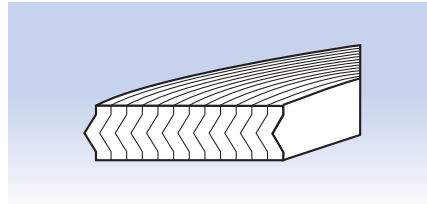

#### Type C

Basic construction style. Suitable for tongue and groove, male and female or flat face and recess flanges.

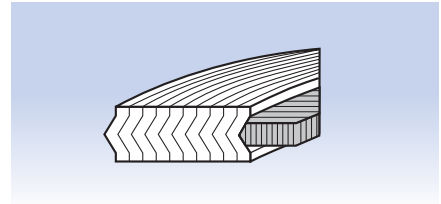

#### Type C/IR

Identical to the Type C but fitted with the protective inner ring which gives high pressure and temperature capabilities with improved sealing performance. Used on male and female flanges.

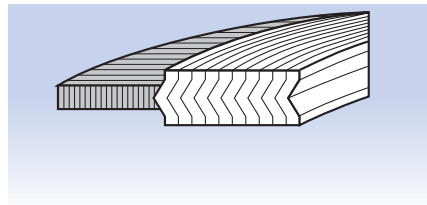

#### Type SG

As Type C but fitted with an external ring which accurately centralises the sealing element. In addition the ring provides extra radial strength and acts as a compression stop. Generally used on raised face and flat face flanges.

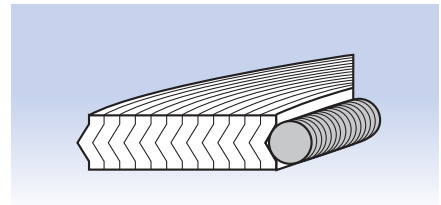

#### Type H and H/IW

In appearance these are identical to Type C but specifically designed for the sealing of manholes, handholes, tubecaps and plugs in boilers and vessels. They can be produced in a wide variety of shapes, the most common being circular, obround, square, oval and diamond. The H/IW incorporates a stainless steel wire on the inner surface which protects the inner windings and reduces the risk of extrusion under compression.

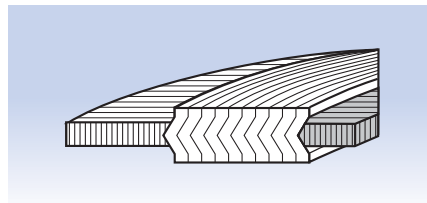

#### Type SG/IR

Identical to the Type SG but also fitted with an inner ring to prevent damage to the gasket bore and inner windings. It also acts as a heat shield and corrosion barrier and improves recovery characteristics and sealing performance.



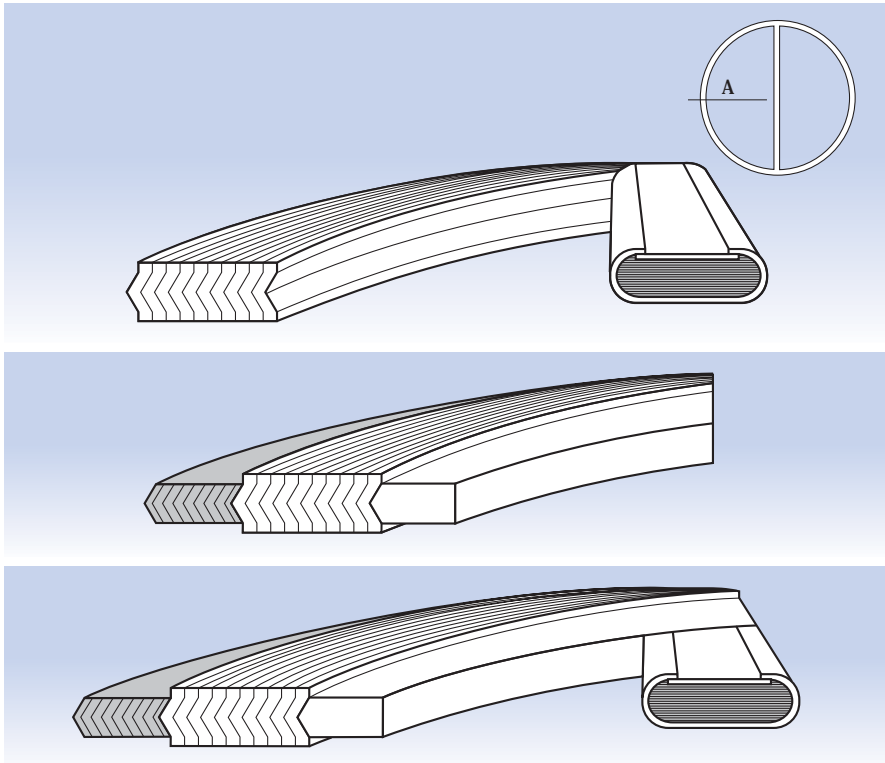

See page 26 for typical pass partition bar configurations.

## Metaflex® manufacturing parameters

The standard Metaflex® Type SG and SG/IR gaskets are produced with a sealing element thickness of 4.5mm and 3.0mm centring ring/inner rings. However, virtually all types are available in a variety of thicknesses from 2.5mm to 7.3mm nominal.

The following tables specify the various nominal and corresponding recommended compressed thicknesses together with maximum and minimum diameters for each thickness.

SIZES NOMINAL THICKNESS	MINIMUM DIAMETER	MAXIMUM DIAMETER
2.5mm (0.098")	22mm (7/8")	300mm (12")
3.2mm (0.125")	10mm (3/8")	760mm (30")
4.5 (0.175")	10mm (3/8")	1520mm (60")
7.3mm (0.285")	60mm (2.3/8")	3550mm (140")*



\* Whilst we do not generally recommend above 3550mm, we have supplied type SG/IR in excess of 5 metres diameter.

## Metaflex® gasket compression

Metaflex® gaskets must be compressed by a specific degree if maximum service potential is to be realised.

NOMINAL THICKNESS	COMPRESSED THICKNESS
2.5mm (0.098")	1.9/2.1mm (0.075/0.85")
3.2mm (0.125")	2.4/2.6mm (0.095/0.105")
4.5 (0.175")	3.2/3.45mm (0.125/0.135")
7.3mm (0.285")	5.00/5.25mm (0.197/0.207")

Note: Due to the compression characteristics of PTFE, full compression may not always be achieved. If flange face contact is essential then special clearances can be considered.

## Type TE

This type is identical to the Type C but is fitted with pass-partition bars for use on heat exchangers and vessels. The bars are usually manufactured metal-jacketed gaskets but can also be solid metal faced with graphite, PTFE or soft jointing material.

## Type WG and WG/IR

Designed to suit the relatively narrow seating space on many heat exchangers by utilising a spirally wound steel centring ring instead of a solid ring. WG/IR has a solid inner ring.

## Type WG/TE and WG/IR/TE

Identical to the WG profile but fitted with partition bars. WG/IR/TE has an inner ring.



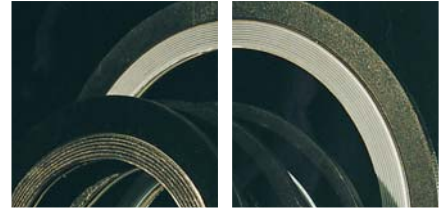

**METAL WINDING STRIP**

- 304
- 304L
- 316
- 316L
- 320
- 310
- 321
- 347
- 17-7 PH
- ALLOY 20
- MONEL 400 & K500

**FILLER MATERIAL**

- STANDARD PURITY GRAPHITE 'SPG'  
(98% MIN. PURITY)
- HIGH PURITY GRAPHITE 'HPG'  
(99.7% MIN. PURITY)
- COMPRESSED NON-ASBESTOS  
FIBRE 'XA'
- PTFE
- HIGH TEMPERATURE FILLER 'HTF'

**TEMPERATURE LIMITS**

- ) 500°C (Oxidising conditions)
- ) 600°C (Inert/reducing media)
- ) 650°C (Steam)
- 500°C
- 260°C
- 1000°C

- NICKEL 200
- INCONEL 600, 625 & X750
- INCOLOY 800 & 825
- TITANIUM
- HASTELLOY B2 & C276
- COPPER
- ZIRCONIUM
- DUPLEX

**INNER & OUTER RING MATERIAL**

CARBON STEEL*	310
304	321
304L	MONEL 400
316	NICKEL 200
316L	INCONEL 600, 625 & X-750
320	INCOLOY 800 & 825

- TITANIUM
- HASTELLOY B2 & C276
- COPPER
- ZIRCONIUM
- DUPLEX
- PTFE (INNER RINGS ONLY)

The most widely used material for winding metal is SS 316L and is usually used with carbon steel or stainless steel flanges. The standard inner ring material is also SS 316L. It is normal practice for the inner ring and windings to be the same as, or compatible with, the flange metal. This practice prevents corrosion and differential expansion problems. For very high temperatures or highly corrosive applications, alternative materials may be chosen for both windings

and inner rings. PTFE inner rings can be supplied for highly corrosive media.

As standard the centring rings are supplied in carbon steel with an anti-corrosion coating/treatment primarily to prevent corrosion in storage. The use of stainless steel for centring rings is quite common where the external flange environment conditions are corrosive to carbon steel, or temperature conditions prohibit the use of carbon steel.

\* As standard supplied with a paint coating to inhibit corrosion during storage. Other protective coatings, eg. zinc plating with a chrome passivate, are available on request.



# Metaflex® Lolode Spiral wound gaskets



Some methods of calculation of the bolt load required to compress conventional spiral wound gaskets, result in figures which appear to over-stress the standard bolting of many ASME B16.5 class 150 and some 300 flanges.

Spiral wound gaskets have been used successfully on these flange classes for many years. However, a lot more attention has recently been paid to the amount of compression that is actually achieved when standard bolting is employed. The replacement of asbestos with expanded graphite (SPG) filler, has improved this situation by producing equivalent sealing performance under lower compressive forces, as well as allowing greater compression for a given bolt load.

It must be acknowledged that on certain flanges, the amount of available bolting may be insufficient to achieve the degree of compression normally recommended by gasket manufacturers, without exceeding the recommended bolt stress levels given in the flange design codes. However, in practise, gaskets have been found to be capable of effecting a good degree of sealing performance, especially at the system pressures associated with class 150 and 300 flanges, even though the gasket may not be fully compressed to the guide ring.



## Typical load-compression comparison

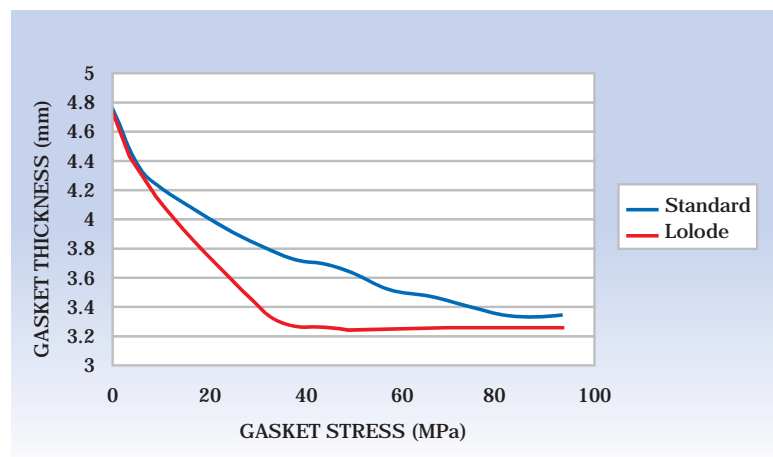

The Lolode gasket has been developed to satisfy those requirements for maximum sealing element compression, using the bolt stress figure of 25,000 p.s.i. given for certain material grades shown in the ASME code. The expanded graphite (SPG) filled Lolode, has the basic design and properties of a standard Metaflex® spiral wound gasket, but it has been carefully engineered to enable compression down to the guide ring under the limited load provided by ASME B16.5 or BS 1560 class 150 or 300 flanges.

Lolode gaskets are available to ASME B16.20 and BS 3381 dimensions to suit class 150 and 300 flanges from 1/2" to 24" nominal bore.

(Note that the large diameter flanges to ASME B16.47 Series A and B do not suffer the same poor ratio of gasket area to bolt area as the smaller flanges such as 3" and 8" class 150, and hence Lolode gaskets are not required for these flanges).

The graph above shows a comparison of the amount of compression obtained at a given gasket stress for the Lolode version compared to a standard Metaflex® SPG filled spiral wound gasket. It can be seen that the Lolode compresses down to the nominal guide ring thickness of 3.3mm at a significantly lower level of stress than the standard gasket.

# Metakamm™ Kammprofile gaskets

Kammprofile gaskets consist of a metal core with concentric serrated grooves on each side and the addition of a soft layer of sealing material bonded to each face. Selection of the metallic core material and sealing layer materials is dependent on the service duty.

The serrated metallic core is very effective for sealing in applications where high temperatures, high pressures and fluctuating conditions exist and can be used without sealing layers, but there is a risk of flange damage, especially at high seating loads. The sealing layers protect the flange surfaces from damage and also offer excellent sealing properties when supported by the serrated metallic core.

## Advantages

- Can seal pressures up to 250 bar.
- Can withstand temperatures up to 1000°C - dependent on core and layer materials used
- Can maintain effective sealing performance in varying temperature and pressure conditions.
- Will not damage flange surfaces and can be removed easily.
- The serrated metallic core can be re-used, subject to inspection after cleaning and re-layering.
- Can be made to suit existing arrangements, without modification.



## Gasket profiles

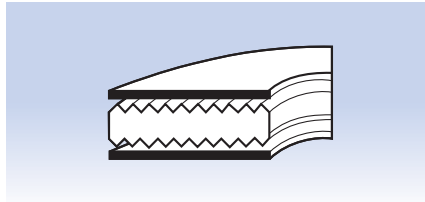

### Type CK

Parallel root core for use in confined location including male and female, tongue and groove and recessed flange arrangements.

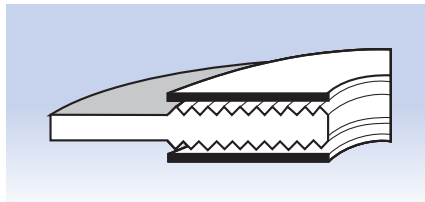

### Type SGK

Parallel root core with integral centring ring for correct gasket positioning within the flange bolt circle. Type SG is recommended for use on standard raised face and flat face flanges.

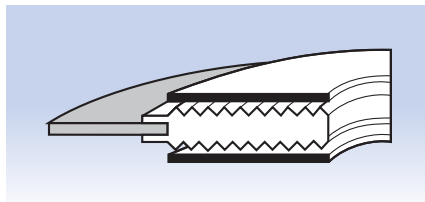

### Type LGK

Parallel root core with loose fitting centring ring which reduces the possibility of damage to the core as a result of mechanical and thermal shock.

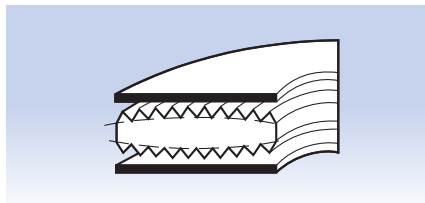

### Type CCK

As above styles, except with a convex root core. This design ensures the highest contact pressure is in the middle of the profile and excellent flow of the soft sealing layer into the flange surface.

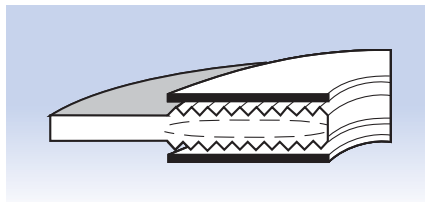

### Type SGCK

This design can be an advantage where flange rotation occurs and only a small seating flange is required for the flanges to become tight.

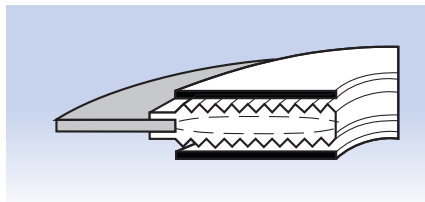

### Type LGCK

Gaskets of this design are particularly effective in fluctuating temperature and/or pressure conditions and for higher temperatures in general.



## Gasket materials

Metakamm™ gaskets are available to order in a wide variety of component materials.

CORE MATERIAL	SOFT FACING MATERIAL	TEMPERATURE LIMITS
304 ) 304L ) 316 ) 316L ) STAINLESS 320 ) STEELS 321 ) 347 ) 310 )	STANDARD PURITY GRAPHITE 'SPG' (98% min. purity) HIGH PURITY GRAPHITE 'HPG' (99.7% min. purity) NON-ASBESTOS FIBRE 'XA' (various proprietary grades)	) 500°C (oxidising conditions) ) 600°C (inert/reducing media) ) 650°C (steam)
Monel 400 & K500 Nickel 200	PTFE	450°C approx.
Inconel 600, 625 & X750 Incoloy 800 & 825	HIGH TEMPERATURE FILLER 'HTF'	260°C
Hastelloy HB2 & C276 Copper Duplex	SOFT METALS: SILVER, ALUMINIUM, etc.	1000°C

## Manufacturing parameters

Normally supplied with a 3.0mm or 4.0mm thick core and covering layers 0.5mm thick, but can also be supplied in other thicknesses.

Diameters from 10mm N.B. upwards can be manufactured and the size limitation for each type of Metakamm™ gasket is as follows:

Type CK & CCK	up to 5000mm diameter
Type SGK & SGCK	up to 2000mm diameter
Type LGK & LGCK	up to 2000mm diameter
Type TE	up to 5000mm diameter
Type EF	up to 5000mm diameter

For heat exchanger applications see page 26 for typical pass partition bar configuration.

## Metakamm™ Easi-fit

In order to facilitate easier fitting and to reduce material and machining costs, larger Metakamm™ gaskets can be supplied as Type EF gaskets with either two or four locating lugs. These lugs aid fitting, as a minimum number of flange bolts need be removed for the gasket to be easily, but accurately positioned.



# Metakamm™ Multifit gaskets

## “One size fits all”

In the most popular piping classes (ASME 150, 300, 600 & DIN PN10-100) only ONE gasket is required for each nominal bore size - 1/2” through to 24” and 10 NB to 600 NB.

Uses well proven Kammprofile gasket technology with specially designed sealing elements and location rings.

### The cost effective Kammprofile

- Kammprofile consistency & performance.
- Self loading.
- Reduces & simplifies inventory.
- Minimises ‘out of stock’ risk.
- Reduces ‘lifetime’ cost.
- Re-usable ‘clip in’ outer guides.
- Re-usable sealing elements - with new facings.
- Ex stock availability for 316L cores with graphite.
- Full range of materials available.
- Other sizes on application.

### How to order

- Quantity.
- Nominal bore & pressure rating, eg 2” 150-600.
- Flange description, eg ASME, DIN.
- Material combination, eg 316L/graphite.

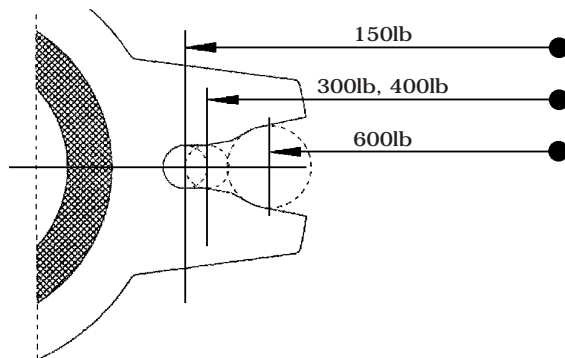

Standard gasket profile

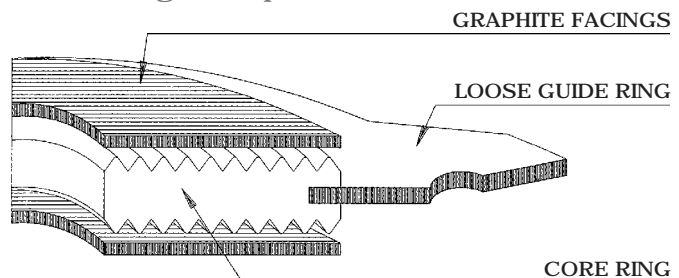

# Spiral wound & Kammprofile gaskets

## Chemical suitability guide

METALLIC COMPONENT	SS 304L, 321, 347	SS 316, 316L	NICKEL 200	MONEL 400	INCONEL 625	METALLIC COMPONENT	SS 304L, 321, 347	SS 316, 316L	NICKEL 200	MONEL 400	INCONEL 625
STEAM	A	A	A	A	A	METHYLALCOHOL (65°C)	C	B	A	A	A
STEAM CONDENSATE	A	A	A	A	A	NAPHTHA (20°C)	A	A	A	A	A
WATER	A	A	A	A	A	NICKEL CHLORIDE SOLUTION (20°C)	A	A	B	B	B
AIR	A	A	A	A	A	NICKEL SULPHATE (hot/cold)	A	A	A	A	A
ACETIC ACID (50% @ boiling)	C	B	B	A	B	NITRIC ACID (50% @ 20°C)	A	A	E	E	A
ACETIC ANHYDRIDE (boiling)	A	A	A	A	A	NITRIC ACID (65% @ boiling)	B	B	E	E	D
ACETONE (boiling)	A	A	A	A	A	OIL - CRUDE (hot/cold)	A	A	A	A	A
ALUMINIUM CHLORIDE (20°C)	D	C	B	B	C	OIL - VEG/MINERAL (hot/cold)	A	A	A	A	A
AMMONIA LIQUOR (boiling)	A	A	C	C	A	OXALIC ACID (10% boiling)	D	C	B	A	B
AMMONIUM CHLORIDE (50% boiling)	B	A	A	A	B	PHENOL	A	A	A	A	A
AMMONIUM NITRATE (boiling)	A	A	E	E	B	PHOSPHORIC ACID (10% @ 20°C)	C	B	B	B	B
ANILINE (concentrated @ 20°C)	A	A	A	A	A	PICRIC ACID (70%)	A	A	O	O	O
BARIUM CHLORIDE (boiling)	B	A	B	A	B	POTASSIUM BICHROMATE (20°C)	A	A	A	A	A
CHROMIUM PLATING BATH (20°C)	A	A	C	C	A	POTASSIUM CHLORIDE (5% boiling)	A	A	A	A	A
CITRIC ACID (15% boiling)	B	A	B	A	A	POTASSIUM HYDROXIDE (50% boiling)	B	A	A	A	A
COPPER SULPHATE (saturated/boiling)	A	A	C	C	C	POTASSIUM NITRATE (5% hot)	A	A	A	A	A
CREOSOTE/TAR (hot)	A	A	A	A	A	POTASSIUM SULPHATE (5% hot)	A	A	A	A	A
ETHER (20°C)	A	A	A	A	A	POTASSIUM SULPHIDE (salt)	A	A	A	A	A
ETHYL ALCOHOL (boiling)	A	A	A	A	A	SEA WATER	A	A	A	A	A
ETHYL CHLORIDE (20°C)	A	A	A	A	A	SEWAGE	A	A	A	A	A
ETHYLENE CHLORIDE (20°C)	A	A	A	A	A	SODIUM CARBONATE (5% @ 65°C)	A	A	A	A	A
FERRIC CHLORIDE (1% @ 20°C)	B	A	B	C	C	SODIUM CHLORIDE (saturated/boiling)	B	A	A	A	A
FLUORINE (20°C)	E	E	A	A	A	SODIUM HYDROXIDE	A	A	A	A	A
FORMALDEHYDE (Formalin 40%)	B	A	A	A	A	SODIUM HYPOCHLORITE (5% still)	B	A	C	C	C
FORMIC ACID (5% @ 65°C, still)	B	A	A	A	A	SODIUM NITRATE (fused)	C	B	A	B	A
FUEL OIL (hot)	A	A	B	B	A	SODIUM SULPHATE (20°C)	A	A	A	A	A
FUEL OIL (+ sulphuric acid)	C	B	B	B	B	SULPHUR DIOXIDE (moist 20°C)	B	A	D	C	C
HYDROCHLORIC ACID (20°C)	E	E	B	B	C	SULPHUR (wet)	B	A	B	B	A
HYDROFLUOSILICIC ACID (20°C)	E	D	A	A	B	SULPHURIC ACID (10% @ 20°C)	C	B	B	A	C
HYDROGEN PEROXIDE (boiling)	B	A	O	O	O	SULPHURIC ACID (fuming @ 20°C)	C	B	C	B	B
HYDROGEN SULPHIDE (wet)	B	A	A	A	A	SULPHUROUS ACID (saturated 190°C)	C	B	E	E	E
KEROSENE	A	A	A	A	A	TANNIC ACID (65°C)	A	A	A	A	A
LACTIC ACID (10% @ 65°C)	C	B	B	B	B	TRICHLORACETIC ACID (20°C)	E	E	B	B	B
LINSEED OIL (20°C)	A	A	A	A	A	ZINC CHLORIDE (5% boiling)	B	B	B	B	B
MAGNESIUM CHLORIDE (5% hot)	C	B	A	A	A	ZINC SULPHATE (25% boiling)	A	A	A	A	A
MAGNESIUM SULPHATE (hot)	A	A	A	A	A						

### Notation:

- A Fully resistant (less than 0.009mm penetration per month)
- B Satisfactory (0.009mm - 0.09mm per month)
- C Fairly resistant (0.09mm - 0.025mm per month)
- D Slightly resistant (0.25mm - 0.9mm per month)
- E Non-resistant (over 0.9mm per month)
- O Insufficient data available

Where chemical compatibility is not indicated, or a chemical is not listed, please consult our technical services team for a recommendation to be made.

Due to the complexity of making a recommendation for any given duty, this section on chemical compatibility is intended only as a guide. The possible effect of elevated temperatures should be considered when determining the compatibility of these products with a chemical. If necessary, please contact our technical services team for assistance.

### Filler and facing materials:

EXPANDED GRAPHITE: See details for Supagraph® Plain Standard Sheet.

HTF (HIGH TEMPERATURE FILLER): When used with suitable winding steel grades, this material resists the majority of common media including; hot oil, fuels, acids, alcohols and esters. It should NOT be used with sulphuric, phosphoric, hydrofluoric or other strong mineral acids.

PTFE (WITH 25% GLASS FIBRE): This material is chemically inert to most media, with a few exceptions as follows:-  
 • It offers only fair resistance to: ammonium hydroxide, bromine, chromic acid, hydrobromic acid, hydrochloric acid, hydrocyanic acid, nitric acid (0-50%), phenol and sodium hydroxide.  
 • It should NOT be used with:- fluorosilicic acid, hydrofluoric acid, hydrogen sulphide solution or sodium silicate.



# Metal jacketed gaskets

These gaskets are specially designed and widely used for heat exchangers, autoclaves, columns, pressure vessels, flue stacks, boilers, gas mains, valve bonnets, pumps and similar services.

The gaskets are manufactured from a soft, pliable filler core surrounded by a metal jacket, chemically and thermally resistant to the working conditions, which may totally or partially enclose the filler.

The majority of these types of gasket are supplied in circular form but can be manufactured to other shapes to suit individual requirements. The method of manufacture enables gaskets to be produced with almost no size limitations. They are produced in different styles to API, ASME DIN and BS standards.



Metal jacketed gaskets are frequently required with pass partition bars, which may be manufactured by two methods, either with 'integral' bars or with bars welded onto the main gasket. Both methods have advantages and we are able to supply to either method of construction.

## Integral bars

This method of construction ensures that the gaskets have uniform hardness around the main periphery of the primary seal and along the pass partition bars. As there is a solid join between the bars and the main gasket, the construction is more robust and eliminates the possibility of seepage of the media into the core of the gasket. This construction is recommended for the sealing of hazardous fluids. We recommend that this style has at least a 10mm radius at all intersections, this maintains a continuous metal overlap, which prevents splitting of the metal.

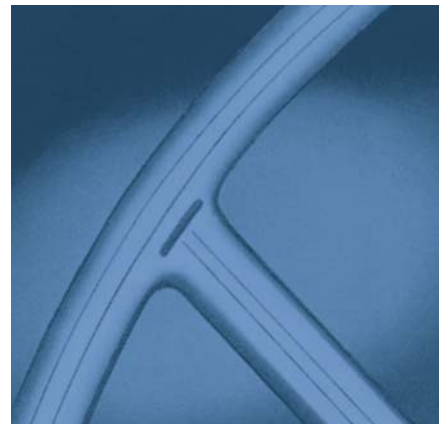
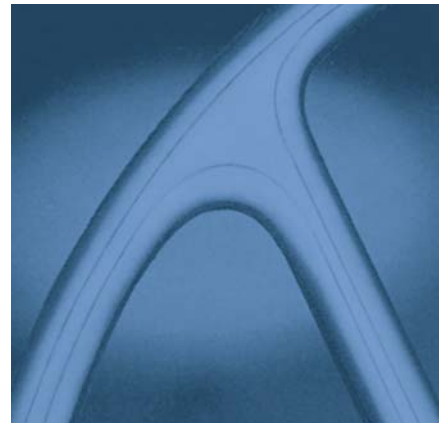

## Welded bars

This method of construction has distinct commercial advantages as it allows full material utilisation. Welding is carried out using methods which ensure that metal hardening is minimised.

## Flange nubbins

Flange nubbins are often used to increase stress and in such cases, care must be taken to install the gaskets with the seamed face on the opposite side.

The gasket seam should be on the opposite side to any flange nubbins

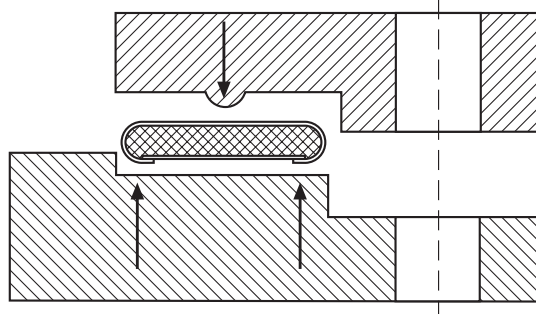

## Metal jacketed gasket styles

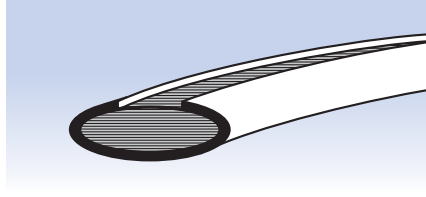

**M120**  
Single jacketed  
Soft filler - open type

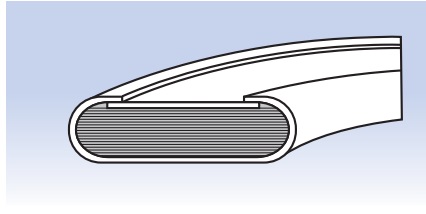

**M123**  
Double jacketed  
Soft filler - totally enclosed

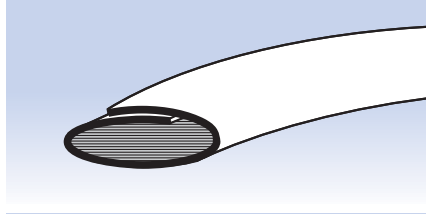

**M124**  
Single jacketed  
Soft filler - totally enclosed

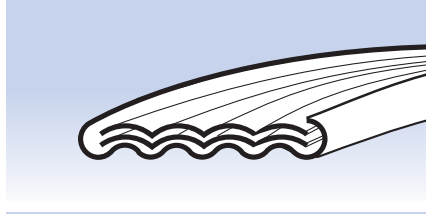

**M129**  
Double jacketed  
Metal filler - corrugated

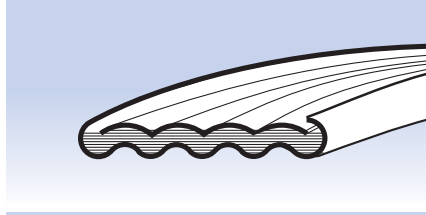

**M126**  
Double jacketed  
Soft filler - corrugated

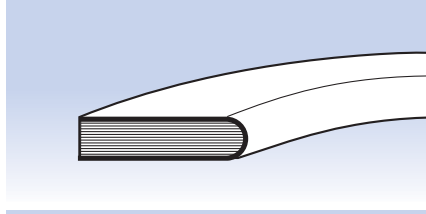

**M130**  
Single jacketed  
Soft filler - open edge outside

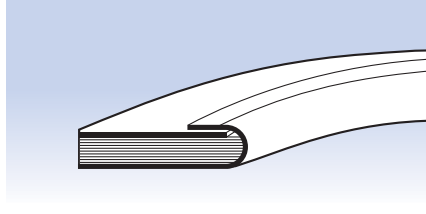

**M131**  
Double jacketed  
Soft filler - open edge outside

## Metal jacketed gasket materials

### Metal Jacket

Metals are only used in the annealed condition and limit the hardness of the metal in line with international standards as shown.

### Fillers

Selection of the correct filler is important and as standard we use a soft non-asbestos filler. This material is constructed from inorganic fibre and inert fillers, suitably bonded, which produces a material having very similar characteristics to those of asbestos millboard. A data sheet on this material is available on request. Alternative fillers include expanded graphite, PTFE, compressed non-asbestos fibre and ceramic fibre.

	MAXIMUM HARDNESS BRINELL
SOFT IRON	90
LOW CARBON STEEL	120
S304 STAINLESS STEEL	160
S316 STAINLESS STEEL	160
S321 STAINLESS STEEL	160
TITANIUM	
BRASS	
COPPER	
ALUMINIUM	
Fe 4/6% CHROME 1/2% MOLY	130
410 11/13% CHROME	170
NICKEL	
MONEL	
INCONEL	

# Heat Exchanger gasket shapes

- Typical pass partition bar configurations

Metal Jacketed Gaskets

Kammprofile Gaskets

Spiral Wound Gaskets

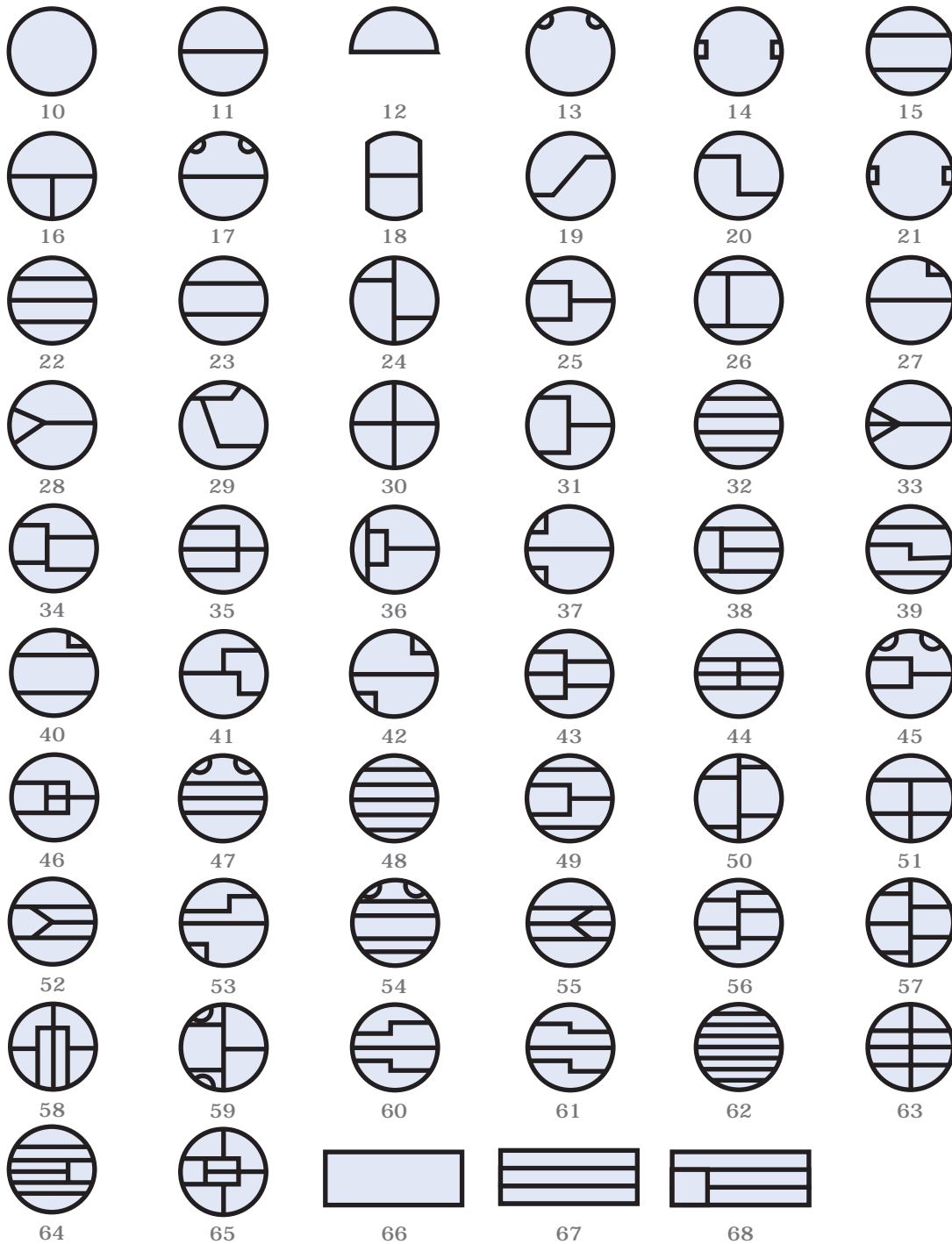



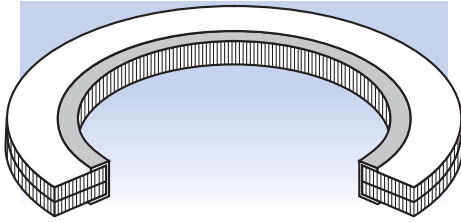

## Eyeletted gaskets

A metal bead (usually stainless steel), is put around the inner periphery of gaskets cut from sheet material to protect the gasket's internal diameter, as well as offering other advantages, some of which are listed below.

Whilst the gaskets can be produced using a wide variety of materials such as CNAF (compressed non-asbestos fibre), they are more commonly required with expanded graphite, normally reinforced with plain nickel or tanged stainless steel.

The region beneath the bead receives greater compression due to the thickness of the metal and thus is more highly stressed than the rest of the joint. This additional compression is more easily achieved with graphite than with other materials.

### Advantages

- Anti blow-out giving extra safety.
- Provides extra strength to the gasket, making it easier to handle and assemble.
- Non contamination of the medium from the gasket material, eg graphite.
- Prevents erosion at high velocities.
- No modification of flange needed and can be made to suit virtually all flanges.
- Range of stainless steel eyelets available to be compatible with most chemicals and compounds.

### Availability

Standard eyelet is made from 316L stainless steel and suitable for ASME or DIN flanges in thicknesses of 1.5mm, 2mm and 3mm. Maximum recommended operating pressures to suit DIN 40 bar and ANSI class 600 flanges.

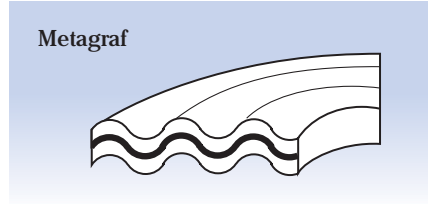

## Metagraf/Metex gaskets

Metagraf has a corrugated metal core, normally stainless steel, with Supagraf® expanded graphite facings. Available as Metagraf PL with a wide chemical compatibility for standard pipeline duties, and Metagraf HX for sealing heat exchangers.

Metex is a robust gasket comprising a flat metal core, (eg. 3mm thick stainless or carbon steel) with Supagraf® expanded graphite facings. It is typically used for large diameter gaskets, as well as heat exchanger duties where seating space is limited.

### Temperature limits

Oxidising atmosphere -200°C to +400°C  
 Steam +650°C Maximum

### How supplied

Metagraf PL	To suit ASME class 150/300 as well as DIN flanges
HX and Metex	Custom made to order

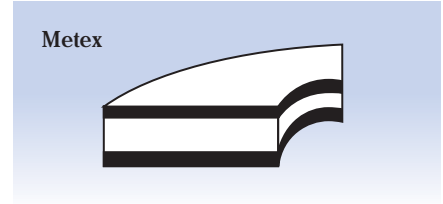
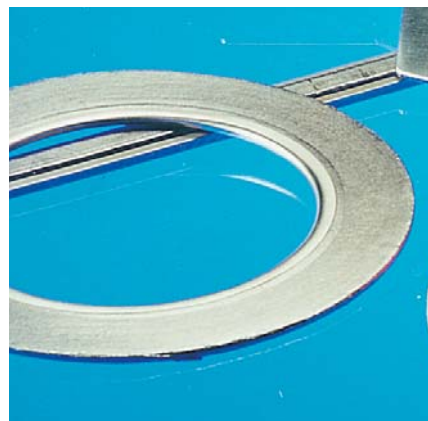

### How to order

- If material is known
  - 1 Quantity
  - 2 Material
  - 3 Thickness
  - 4 Nominal bore and flange specification or sizes
- If unsure of material - all above plus full operating conditions, eg. temperature, pressure, media.



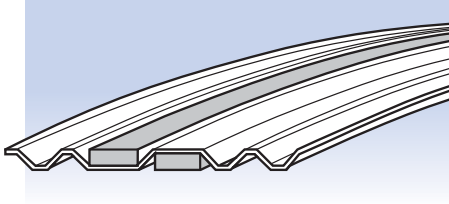

## Metcom Gaskets

These are another variation of a graphite gasket, consisting of a thin corrugated sheet steel joint with pairs of grooves pressed concentrically from either side. The grooves are relatively narrow (approx. 6mm) and two adjacent grooves are filled with a bead of graphite tape, 3mm wide. When compressed between flanges, there is a reactive force from the metal corrugations which combine with the graphite enhances the sealing capability. The corrugations also assist in retaining the graphite.

This type of gasket is more robust and easier to fit than a sheet graphite cut joint. It has the advantage of being thinner than a spiral wound gasket and therefore can be utilised to replace thin C.A.F. gaskets in those instances where use of spiral wound joints could disrupt pipe alignment due to their additional thickness.

The gasket can be safely tightened to high levels of bolt stress.

### Advantages

- One size fits 150 through to 2500lbs flanges.
- Gasket is self locating.
- Once torqued, never needs re-tightening.

### Availability

#### Multifit

1/2" to 12" class 150-2500  
(equivalent DIN sizes up to 300mm N.B.)

#### Inside bolt circle

1/2" to 24" class 150-2500  
(individual class inside bolt circle joint rings).

Other sizes on application.

The Metcom is designed with a profiled metal retainer ring so that a single gasket fits all flanges within a pipe size. The drawing shows how a Metcom can be fitted to the bolt circles on all flange ratings from 150lbs to 2500lbs.

### Sealing rings

Flexible graphite has been widely recognised as the best material, which combines the best thermal as well as chemical stability (nuclear grade available). PTFE is available in those applications where flexible graphite is not suitable.

## Metcom Materials

METAL CORE	304, 316L (other metals available for specific applications)
SEALING MATERIAL	GRAPHITE STANDARD (PTFE OPTIONAL) THICKNESS 0.35mm TO 0.5mm DENSITY 0.7gm/cc minimum
NOMINAL OVERALL THICKNESS	1.5mm
COMPRESSED THICKNESS	0.5mm
PRESSURE RATINGS	VACUUM TO CLASS 2500 DEPENDING ON TEMPERATURE
TEMPERATURE CAPABILITIES	CRYOGENIC TO 500°C OXIDISING: TO 650°C STEAM

## Metcom Multifit configuration

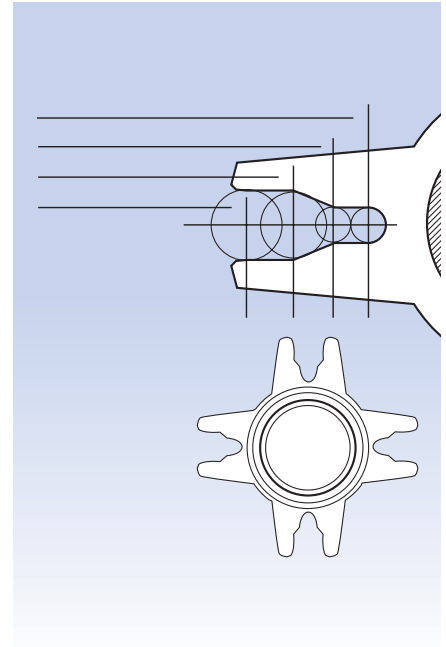



## Metallic Gaskets



### Top performance under extreme conditions

James Walker Moorflex's precision machining creates a product with the high performance standards needed for today's extremely demanding applications. Moorflex use only the best forged metals, no welded rings, which undergo a stringent machining process to ensure that close tolerances and smooth contact surfaces are rigidly maintained.

Quality is guaranteed by a strict series of tests and process quality control, and Moorflex's final inspection assures total compliance with customer specifications. Hence, engineers confidently continue to specify Moorflex gaskets for their requirements in both original equipment and replacements.

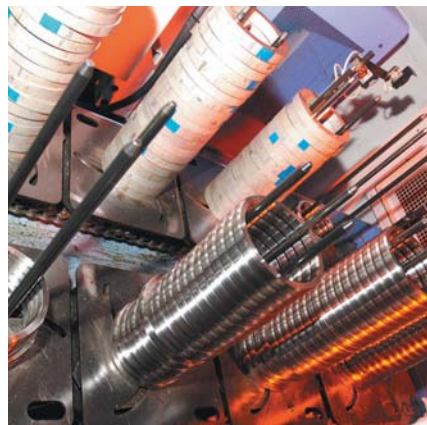

## Introduction

### Origin and application

The sealing of well-head valves and fittings in exploration and production areas of the oil and natural gas industry has constantly presented a higher pressure requirement than has been necessary in most other major manufacturing processes.

To meet this requirement, the American Petroleum Institute developed ring joint flanges and their accompanying gasket requirement and issued standards covering "general use" and "oil field use". These two categories are now covered by ASME and API standards respectively, of similar dimension but differently rated in material strength to allow the API flange to operate at a higher working pressure.

The solid metal gasket provides an excellent mechanical joint and has almost universal acceptance in the oil, petroleum and chemical processing industries where high mechanical and thermal performance is required.

### Typical uses

- High pressure oil field drilling and production equipment.
- Pressure vessels.
- Pipeline valves.
- Gas and chemical plants.

Under their Moorside™ brand James Walker Moorflex are leading manufacturers of the complete range of solid metal ring joint gaskets. The gaskets are manufactured to API 6A, ASME B16 20 and BS7076 Pt 2 standards and to customers' own specifications.



# Moorside™ Metal ring joint gaskets

## Protection

Soft iron and low carbon steel ring joint gaskets to API Standard 6A are supplied with zinc plating to 0.0002" - 0.0005" thick unless otherwise specified. Other platings are also available if preferred. Unplated rings are treated with a rust preventative fluid.

During storage and handling it is very important that the mating faces (the oval radius or the chamfered face) are not damaged as this can lead to leakage when the ring joint is used in its particular application.

To afford the maximum degree of protection, Moorflex offer as an extra feature individual vacuum packaging. Gaskets are vacuum packed using a strong clear film onto a stout backing board. This style of packaging ensures full protection of the gasket, whilst allowing visual inspection of its condition and marking.

## How to order

The styles described are manufactured as standard and are available ex-stock or to short lead-times. When ordering please submit the following data:

- Gasket standard.
- Relevant ring number or nominal pipe size with rating.
- Material required.
- Oval or octagonal shape for Style 'R' gaskets.
- Quantity and required delivery.



## Materials

Gasket metal should be selected to suit the service conditions and should be of a hardness lower than the flange metal. At Moorflex, the annealing process of the metal and the machining is carefully controlled to keep the hardness of the gasket below the maximum allowable, to ensure correct flow and sealing without damage to the flange surfaces.

Checks carried out during manufacture ensure that the hardness of the finished product does not exceed the figures stated below.

The principal types of material are:

METAL	MAXIMUM HARDNESS IDENTIFICATION ROCKWELL B
SOFT IRON	56 (90 BHN) D
LOW CARBON STEEL	68 (120 BHN) S
F5 ALLOY STEEL (4/6% Cr, 1/2% Mo)	72 (130 BHN) F5
410 ALLOY STEEL (11/13% Cr)	86 (170 BHN) S410
304 STAINLESS STEEL	83 (160 BHN) S304
304L STAINLESS STEEL	83 (160 BHN) S304L
316 STAINLESS STEEL	83 (160 BHN) S316
316L STAINLESS STEEL	83 (160 BHN) S316L
347 STAINLESS STEEL	83 (160 BHN) S347
321 STAINLESS STEEL	83 (160 BHN) S321
825 NICKEL ALLOY	93 (200 BHN) 825

Other stainless and super alloy steels, Duplex, Monel, Inconel, Incoloy, Nickel and other materials are available. Based on almost 50 years of experience, Moorflex have established specifications to ensure gasket suitability. Certification and compliance with NACE MRO175 are standard features.

## Identification and traceability

For convenience in ordering, numbers are assigned to gaskets and prefixed by the letter 'R', 'RX' or 'BX', followed by the material identification. Marking is effected so as not to injure the contact faces, nor to harmfully distort the gasket. Moorflex use only low stress DOT stamps approved to NACE standards in order to ensure that stresses are not introduced into the gasket.

All non-API gaskets are typically marked Moorside R45 S316. Gaskets complying to API Standard 6A are additionally marked with API Monogram Licence No., Product Specification Level 4 and date of manufacture. (It is standard procedure for Moorflex to supply API 6A gaskets to PSL4).

All API gaskets are typically marked:-

Moorside  $\Phi$  6A-0038 R45 S316-4 12/2001 (December 2001).

Traceability of material and constant monitoring of manufacture are essential for effective quality control. All Moorside ring joint gaskets carry a Material Reference Number, which directly relates to the batch of material from which it was manufactured. The MRN number is applied to the gasket in the same way as the identification marks. This reference is included in material certificates, thus ensuring full traceability of supply.

Moorside or  $\textcircled{M}$  denotes James Walker Moorflex trade mark.

## Gasket styles and types

Series 'R'  
Oval

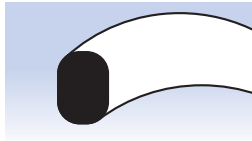

Series 'R'  
Octagonal

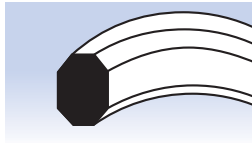

The type R oval configuration is the original ring joint design and was followed by the type R octagonal which offered more specific sealing contact areas. Both types can be used with flanges having the standard ring joint flat bottom groove and hold off flanges by a specified amount, relying entirely on correctly applied initial bolt-load for their proper operation in service.

Available in ring numbers R11 through R105 to suit the following flange specifications:

### NOMINAL PIPE SIZE

1/2" - 24"

26" - 36"

26" - 36"

1 1/2" - 20"

### CLASS RATING AND STANDARD

150 - 2500 ASME B16.5 and BS1560

300 - 600 MSS SP44 and BS 3293

900 MSS SP44

API Spec. 6A

## Series 'R' manufactured to the standards ASME B 16.20 - API Std 6A BS EN 12560-5

Ring Number	Pitch	Width	HEIGHT			NOMINAL BORES					
			Oval	Octagonal	Width of flat on octagonal ring	Class 150	Class 300	Class 600	Class 900	Class 1500	Class 2500
R11	1.344	0.25	0.44	0.38	0.17		0.5	0.5			
R12	1.563	0.313	0.56	0.5	0.206				0.5	0.5	
R13	1.688	0.313	0.56	0.5	0.206		0.75	0.75			0.5
R14	1.75	0.313	0.56	0.5	0.206				0.75	0.75	
R15	1.875	0.313	0.56	0.5	0.206	1					
R16	2	0.313	0.56	0.5	0.206		1	1	1	1	0.75
R17	2.25	0.313	0.56	0.5	0.206	1.25					
R18	2.375	0.313	0.56	0.5	0.206		1.25	1.25	1.25	1.25	1
R19	2.563	0.313	0.56	0.5	0.206	1.5					
R20†	2.688	0.313	0.56	0.5	0.206		1.5	1.5	1.5	1.5	
R21	2.844	0.438	0.69	0.63	0.305						1.25
R22	3.25	0.313	0.56	0.5	0.206	2					
R23†	3.25	0.438	0.69	0.63	0.305		2	2			1.5
R24†	3.75	0.438	0.69	0.63	0.305				2	2	
R25	4	0.313	0.56	0.5	0.206	2.5					
R26†	4	0.438	0.69	0.63	0.305		2.5	2.5			2
R27†	4.25	0.438	0.69	0.63	0.305				2.5	2.5	
R28	4.375	0.5	0.75	0.69	0.341						
R29	4.5	0.313	0.56	0.5	0.206	3					
R30	4.625	0.438	0.69	0.63	0.305		3	3			
R31†	4.875	0.438	0.69	0.63	0.305		3	3	3		
R32	5	0.5	0.75	0.69	0.341						3
R33	5.188	0.313	0.56	0.5	0.206	3.5					
R34	5.188	0.438	0.69	0.63	0.305		3.5	3.5			
R35†	5.375	0.438	0.69	0.63	0.305					3	
R36	5.875	0.313	0.56	0.5	0.206	4					
R37†	5.875	0.438	0.69	0.63	0.305		4	4	4		
R38	6.188	0.625	0.88	0.81	0.413						4
R39†	6.375	0.438	0.69	0.63	0.305					4	
R40	6.75	0.313	0.56	0.5	0.206	5					
R41†	7.125	0.438	0.69	0.63	0.305		5	5	5		
R42	7.5	0.75	1	0.94	0.485						5
R43	7.625	0.313	0.56	0.5	0.206	6					
R44†	7.625	0.438	0.69	0.63	0.305					5	
R45†	8.313	0.438	0.69	0.63	0.305		6	6	6		
R46†	8.313	0.5	0.75	0.69	0.341					6	
R47†	9	0.75	1	0.94	0.485						6
R48	9.75	0.313	0.56	0.5	0.206	8					
R49†	10.625	0.438	0.69	0.63	0.305		8	8	8		

All dimensions are in inches. † Denotes API Std. 6A Ring Joint Gaskets.

Ring Number	Pitch	Width	HEIGHT			NOMINAL BORES					
			Oval	Octagonal	Width of flat on octagonal ring	Class 150	Class 300	Class 600	Class 900	Class 1500	Class 2500
R50†	10.625	0.625	0.88	0.81	0.413					8	
R51	11	0.875	1.13	1.06	0.583						8
R52	12	0.313	0.56	0.5	0.206	10					
R53†	12.75	0.438	0.69	0.63	0.305		10	10	10		
R54†	12.75	0.625	0.88	0.81	0.413					10	
R55	13.5	1.125	1.44	1.38	0.78						10
R56	15	0.313	0.56	0.5	0.206	12					
R57†	15	0.438	0.69	0.63	0.305		12	12	12		
R58	15	0.875	1.13	1.06	0.583					12	
R59	15.625	0.313	0.56	0.5	0.206	14					
R60	16	1.25	1.56	1.5	0.879						12
R61	16.5	0.438	0.69	0.63	0.305		14	14			
R62	16.5	0.625	0.88	0.81	0.413				14		
R63†	16.5	1	1.31	1.25	0.681					14	
R64	17.875	0.313	0.56	0.5	0.206	16					
R65†	18.5	0.438	0.69	0.63	0.305		16	16			
R66†	18.5	0.625	0.88	0.81	0.416				16		
R67	18.5	1.125	1.44	1.38	0.78					16	
R68	20.375	0.313	0.56	0.5	0.206	18					
R69†	21	0.438	0.69	0.63	0.305		18	18			
R70†	21	0.75	1	0.94	0.485				18		
R71	21	1.125	1.44	1.38	0.78					18	
R72	22	0.313	0.56	0.5	0.206	20					
R73†	23	0.5	0.75	0.69	0.641		20	20			
R74†	23	0.75	1	0.94	0.485				20		
R75	23	1.25	1.56	1.5	0.879					20	
R76	26.5	0.313	0.56	0.5	0.206	24					
R77	27.25	0.625	0.88	0.81	0.413		24	24			
R78	27.25	1	1.31	1.25	0.681				24		
R79	27.25	1.375	1.75	1.63	0.977					24	
R80	24.25	0.313		0.5	0.206	22					
R81	25	0.563		0.75	0.377		22	22			
R82†	2.25	0.438		0.63	0.305						
R84†	2.5	0.438		0.63	0.305						
R85†	3.125	0.5		0.69	0.341						
R86†	3.563	0.625		0.81	0.413						
R87†	3.938	0.625		0.81	0.413						
R88†	4.875	0.75		0.94	0.485						
R89†	4.5	0.75		0.94	0.485						
R90†	6.125	0.875		1.06	0.583						
R91†	10.25	1.25		1.5	0.879						
R92	9	0.438	0.69	0.63	0.305						
R93	29.5	0.75		0.94	0.485		26	26			
R94	31.5	0.75		0.94	0.485		28	28			
R95	33.75	0.75		0.94	0.485		30	30			
R96	36	0.875		1.06	0.583		32	32			
R97	38	0.875		1.06	0.583		34	34			
R98	40.25	0.875		1.06	0.583		36	36			
R99†	9.25	0.438		0.63	0.305						
R100	29.5	1.125		1.38	0.78				26		
R101	31.5	1.25		1.5	0.879				28		
R102	33.75	1.25		1.5	0.879				30		
R103	36	1.25		1.5	0.879				32		
R104	38	1.375		1.63	0.977				34		
R105	40.25	1.375		1.63	0.977				36		

Series 'RX'

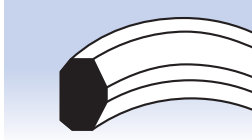

As well-head pressures increased to 700 bar (10,000lb/in<sup>2</sup>) and beyond, flanges designed with type 'R' oval or octagonal rings became excessively heavy, requiring impracticably large bolts to perform the

double duty of holding pressure while keeping the gasket compact.

The solution to this problem was found in higher strength materials and the development of the 'RX' and 'BX' series joint which are pressure energised. (The higher the contained pressure, the tighter the seal).

The 'RX' Style Ring Joint has the unique self-sealing action. The outside bevels of the ring make the initial contact with the groove as the flanges are brought together,

thus pre-loading the gasket against the grooved outer surfaces. Internal pressure during service increases this loading and, therefore, the gasket's sealing performance.

Available in ring numbers RX20 through RX215 to suit the following flange specifications:

**NOMINAL PIPE SIZE**  
1 1/2" - 20"

**CLASS RATING AND STANDARD**  
720 - 5,000 API 6B Flanges

## Series 'RX' manufactured to the standards ASME B 16.20 - API Std 6A

Ring No.	GASKET DIMENSIONS			PRESSURE CLASS RATING			
	I/D	O/D	Height	720-960 2000	2900	3000	5000
				Nominal Pipe Size			
RX 20	2.313	3.000	0.750	1.1/2		1.1/2	
RX 23	2.672	3.672	1	2			
RX 24	3.234	4.172	1			2	2
RX 25	3.625	4.313	0.750				3.1/8
RX 26	3.469	4.406	1	2.1/2			
RX 27	3.719	4.656	1			2.1/2	2.1/2
RX 31	4.359	5.297	1	3		3	
RX 35	4.859	5.797	1				3
RX 37	5.359	6.297	1	4		4	
RX 39	5.859	6.797	1				4
RX 41	6.609	7.547	1	5		5	
RX 44	7.109	8.047	1				5
RX 45	7.797	8.734	1	6		6	
RX 46	7.688	8.750	1.125				6
RX 47	8.094	9.656	1.625				8
RX 49	10.109	11.047	1	8		8	
RX 50	9.844	11.156	1.250				8
RX 53	12.234	13.172	1	10		10	
RX 54	11.969	13.281	1.250				10
RX 57	14.484	15.422	1	12		12	
RX 63	15.266	17.391	2				14
RX 65	17.984	18.922	1	16		16	
RX 66	17.719	19.031	1.250				
RX 69	20.484	21.422	1	18		18	
RX 70	20.094	21.656	1.625				
RX 73	22.406	23.469	1.250	20		20	
RX 74	22.094	23.656	1.625				
RX 82	1.734	2.672	1		1		
RX 84	1.984	2.922	1		1.1/2		
RX 85	2.484	3.547	1		2		
RX 86	2.891	4.078	1.125		2.1/2		
RX 87	3.266	4.453	1.125		3		
RX 88	4.109	5.484	1.250		4		
RX 89	3.672	5.109	1.250		3.1/2		
RX 90	5.188	6.875	1.750		5		
RX 91	8.922	11.297	1.781		10		
RX 99	8.734	9.672	1	8		8	
RX 201	1.573	2.026	0.445				1.3/8
RX 205	2.016	2.453	0.437				1.13/16
RX 210	3.094	3.844	0.750				2.9/16
RX 215	4.609	5.547	1				4 .1/16

All dimensions are in inches. † Denotes API Std. 6A Ring Joint Gaskets.



Designed to API specifications for use with grooved flanges on special applications involving high pressure up to 20,000 p.s.i. the 'BX' series is available in ring numbers BX 150 through BX 303 to suit the following flange specifications:

Style 'BX' Ring Joint Gaskets can only be used with special 'BX' grooves and are not interchangeable with the Style 'RX' series.

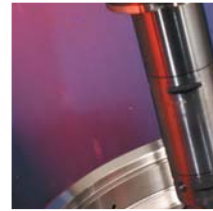
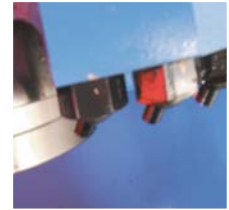

<b>NOMINAL PIPE SIZE</b> 1 <sup>11/16</sup> " - 21 <sup>1/4</sup> "	<b>CLASS RATING AND STANDARD</b> 5,000-20,000 API 6 BX Flanges
--	--

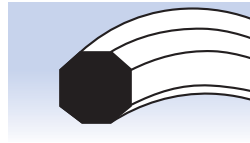

Series 'BX'

## Series 'BX' manufactured to the standards ASME B 16.20 - API Std 6A

GASKET DIMENSIONS				PRESSURE CLASS RATING					
Ring No.	I/D	O/D	Height	2000	3000	5000	10000	15000	20000
Nominal Pipe Size									
BX 150	2.110	2.842	0.366				1.11/16	1.11/16	
BX 151	2.250	3.008	0.379				1.13/16	1.13/16	
BX 152	2.528	3.334	0.403				2.1/16	2.1/16	2.1/16
BX 153	3.078	3.974	0.448				2.9/16	2.9/16	2.9/16
BX 154	3.624	4.600	0.488				3.1/16	3.1/16	3.1/16
BX 155	4.705	5.825	0.560				4.1/16	4.1/16	4.1/16
BX 156	7.901	9.637	0.733				7.1/16	7.1/16	7.1/16
BX 157	9.941	11.593	0.826				9	9	
BX 158	12.038	13.860	0.911				11	11	11
BX 159	14.776	16.800	1.012				13.5/8	13.5/8	13.5/8
BX 160	14.768	15.850	0.938			13.5/8			
BX 161	18.071	19.347	1.105			16.3/4			
BX 162	17.600	18.720	0.560			16.3/4	16.3/4	16.3/4	
BX 163	20.528	21.896	1.185			18.3/4			
BX 164	20.527	22.463	1.185				18.3/4	18.3/4	
BX 165	23.139	24.595	1.261			21.1/4			
BX 166	23.140	25.198	1.261				21.1/4		
BX 167	28.864	29.896	1.412	26.3/4					
BX 168	28.864	30.128	1.412		26.3/4				
BX 169	5.813	6.831	0.624				5.1/8		
BX 170	7.464	8.584	0.560				6.5/8	6.5/8	
BX 171	9.409	10.529	0.560				8.9/16	8.9/16	
BX 172	11.993	13.113	0.560				11.5/32	11.5/32	
BX 303	32.237	33.573	1.494	30	30				

## Transition rings

### Description

Transition rings are used for sealing ring type joints in which the mating flanges have different ring groove diameters. These can be made in any standard ring joint gasket metal. Popular transition combinations are R23/R24, R26/R27, R49/R50 and R65/R66.

Other sizes made with oval or octagonal facings are available to order. When ordering please specify which cross-section is preferred.

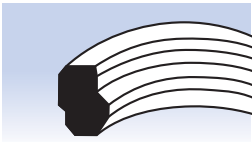

Transition rings



## PTFE inner rings

### Description

Moorflex PTFE inner rings are designed to occupy the cavity between the flange bore and ring joint, fitting closely to the internal diameter of the ring joint and having a small clearance from the bore of the flange.

The use of these components ensures that the effects of discontinuity in pipe bore smoothness are considerably reduced. Turbulence of flow, accumulation of sediment which will not be removed by normal descaling and pig cleaning equipment, and the possibility of corrosion or erosion of flange and joint surfaces are minimised.

Inserts for type 'R' joints have a coarse machined finish, whilst type 'RX' inserts have a deeper grooved profile to control spread under compression within the clearance allowance from the flange bore. Ports permit pressure access to the ring joint to aid venting in the case of sudden system decompression.

### Material

Moorflex PTFE inner rings for metallic ring joint gaskets are manufactured from pure PTFE which is chemically inert to nearly all substances. Only molten alkali metals, fluorine and some fluorine compounds at high temperatures and pressures have been known to affect it. PTFE is also suitable for a wide range of temperatures from -200°C to +250°C.

### How to order

Inserts are available to suit all metallic ring joint gaskets, and may be ordered by supplying the same information specified for metal ring gaskets.

## Flange guard protectors

### Description

Moorflex neoprene flange guard protectors may be fitted externally to ring joint gaskets, and ensure that the ingress of moisture and dirt in the joint area is minimised. The installation of flange guard protectors minimises corrosion of the outer flange area, bolts and gasket, and assists in the ease of dismantling.

### Material

Moorflex flange guard protectors are manufactured from closed cell neoprene sponge. In use, the material is compressed to ensure the necessary degree of resilience to prevent the ingress of moisture, whilst not allowing the passage of moisture through the material.

### How to order

Flange guard protectors are available to suit all metallic ring joint gaskets, and may be ordered by supplying the same information specified for metal ring joint gaskets.



# Moorside™ Rubber coated ring joint gaskets

## Application

A requirement has been established in the testing of valves and well-head assemblies for a robust gasket similar to a metal ring joint gasket, which would allow the user to achieve a seal in standard RTJ type flanges without damage to the flange connections. It is imperative that the sealing mechanism is similar to that which will be used in the final assembly.

James Walker Moorflex have established a range of reusable metallic gaskets with rubber coatings to solve this problem.

## Manufacture

The gasket consists of a standard soft iron metal ring joint, which is encapsulated in nitrile rubber. The profile of the nitrile rubber coating is designed to ensure that a seal is made by the API ring joint, (a secondary seal is made by the flex-tips), and that both ring joint and flanges are protected by the provision of outer and inner ring guards.

Total encapsulation of the metal gasket ensures full protection of the RTJ grooves.



## Gasket styles

Style 'R', and 'RX' rubber coated ring joint gaskets are used in style 'R' and 'RX' assemblies, and style 'BX' rubber coated ring joint gaskets are used in style 'BX' flange assemblies. The metallic 'BX' gaskets are manufactured with an increased height, to allow the provision of the outer and inner ring guards.

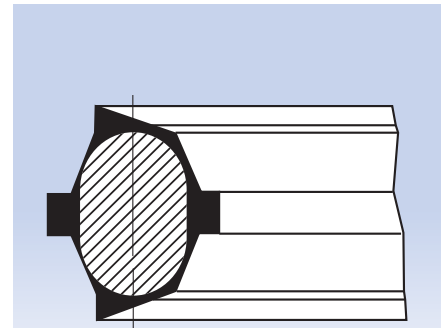

Style R, RX

## Size range

The rubber coating is bonded to the gasket in a precise metallic mould, and Moorflex have established a range of moulds to cover most requirements. The following items are normally held in stock.

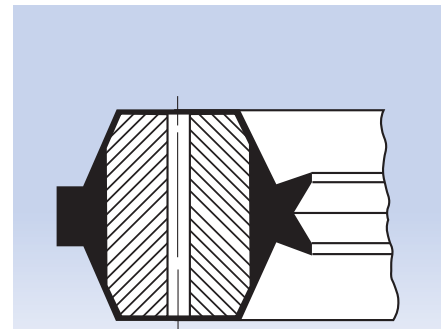

Style BX

### R, RX TYPE

R, RX20  
R, RX23  
R, RX24  
R, RX26  
R, RX27  
R, RX31  
R, RX35  
R, RX37  
R, RX39  
R, RX41  
R, RX44  
R, RX45  
R, RX47  
R, RX49  
R, RX50  
R51  
R, RX53  
R, RX54  
R, RX57

### R, RX TYPE CONTINUED

R58  
R61  
R62  
R, RX63  
R, RX65  
R, RX66  
R67  
R, RX69  
R, RX70  
R71  
R, RX73  
R, RX74  
R, RX20  
R75  
R77  
R78  
R79  
R95  
R102

### BX TYPE

BX150  
BX151  
BX152  
BX153  
BX154  
BX155

### BX TYPE CONTINUED

BX156  
BX157  
BX158  
BX159  
BX160  
BX169



# Machined metal gaskets

In addition to the manufacture of metal ring joint gaskets, James Walker Moorflex manufactures a range of metallic gaskets to international standards and specifications. Manufacturing excellence, reliability of performance and quality control are essential to ensure the operation of metallic gaskets of specialist nature and complex profiles, and the extensive facilities available to Moorflex provide the assurance required from such precision components. Examples of some products are listed here, and more detailed information is available upon request.

## Materials

Metallic gaskets are available in a range of materials including soft carbon steel, stainless and alloy steels, Duplex, Monel, Inconel, Incoloy and Nickel. Other materials are available and of note is S316L Urea Grade Stainless Steel which is widely used in highly corrosive environments, particularly where lens gaskets are specified.

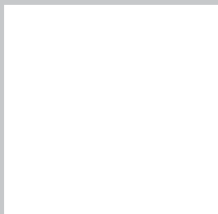

## Gasket profiles

### Lens Gaskets

Are widely used in high pressure applications and are resistant to overstressing. Manufacture is in accordance with DIN 2696 PN 64 to 400 and DN 10 to 300, and are also available in blanking-type form.

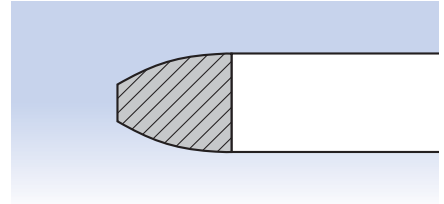

### Convex Gaskets

May be used where centralised loading of the gasket is preferable by a reduction in area.

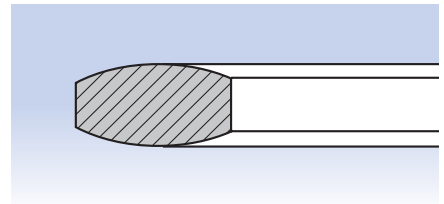

### Wedge Gaskets

Are positively located to provide a seal in cylindrical applications. The lip of the gasket is energised by either bolting or internal pressure.

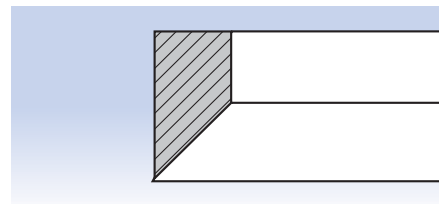

### Double Cone Gaskets

Moorflex are able to manufacture double-cone gaskets up to 2000mm diameter. These gaskets are suitable for large diameter, high pressure applications.

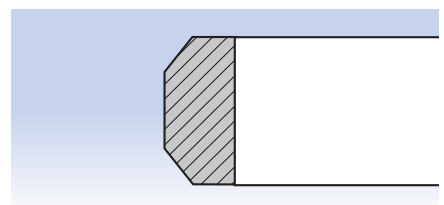

### Weld Ring Gaskets

Are suitable for critical applications where a leak-proof joint is essential. Sealing is achieved by welding the two gasket halves together.

A secondary backup gasket may be fitted where desirable.

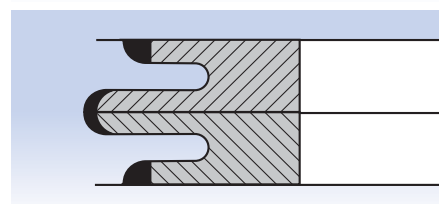

### Ring Joint Orifice/Blanking Gaskets

Also available as Spectacle type.

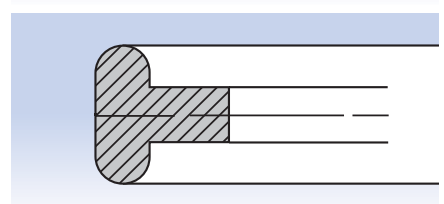



# Custom designed gaskets

## Special designs...

James Walker Moorflex, under its 'Moorside' brand, has been involved in the manufacture of metallic gaskets for the oil and gas industries for almost 50 years, first acquiring a licence in accordance with the requirements of the American Petroleum Institute in 1963. Based on the continued supply of standard product to original equipment manufacturers in the oilfield industry, a confidence and level of expertise has been achieved which has allowed progression into the supply of more complex metal gaskets. In addition to metal seals and gaskets, a portfolio of associated parts has been established. A selection of these items are listed as follows:

- Metal to Metal Gaskets
- Metal Lip Seals
- Assembled Metal Seals
- Lock Down Rings
- Thrust Rings
- Lantern Rings
- Seal Energising Rings
- Pack Off Bodies

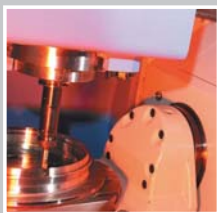

## ...proprietary components

All products are manufactured in partnership between the original equipment manufacturer and Moorflex, and co-operation exists throughout the design and manufacturing stages. Whilst sub-contract machining is an option, based on our extensive knowledge of materials utilised in the manufacture of oilfield equipment, Moorflex take full responsibility for the complete supply of the product, including material sourcing, manufacture, sub-contract

operations, finishing processes, testing and heat treatment. Confidentiality agreements covering the manufacture of proprietary parts are willingly entered into and honoured. Components are manufactured in a range of materials including carbon, alloy, stainless and increasingly, high nickel alloy steels, as well as customer in-house standards incorporated in Bills of Material and drawings.



## Finishing processes

- Xylan/PTFE
- Zinc Phosphate
- Molybdenum Disulfide
- Silver
- Zinc
- Cadmium

## Testing

- Ultrasonic
- Magnetic Particle Inspection
- Liquid Dye Penetrant

## Heat treatments

- Nitriding
- Vacuum Annealing
- Stress Relieving

James Walker Moorflex has specific expertise in the manufacture of annular products up to 2.3 metres diameter on CNC equipment, typically incorporating complex sealing profiles and precise sections. In addition to sophisticated CNC turning equipment, CNC vertical machining and drilling facilities enable the company to supply precise annular rings incorporating radial and tangential drilling, slotting and threaded parts from 10mm to 2300mm diameter.

Incorporated within this feature are several examples of proprietary parts which encapsulate the manufacturing abilities of James Walker Moorflex.

Our Quality Assurance approvals to ISO 9001:2000 and API Spec 6A and Q1, reliability of supply and commercial integrity ensure customer satisfaction.



Information in this publication and otherwise supplied to users is based on our general experience and is given in good faith, but because of factors which are outside our knowledge and control and affect the use of products, no warranty is given or implied with respect to such information. Specifications are subject to change without notice. Statements of operating limits quoted in this publication are not an indication that these values can be simultaneously applied.



### HEALTH WARNING:

If PTFE (e.g. Fluolion) products are heated to elevated temperatures, fumes will be produced which may give unpleasant effects, if inhaled. Whilst some fumes are emitted below 300°C, the effect at these temperatures is negligible. Care should be taken to avoid contaminating tobacco with PTFE particles or dispersion which may remain on hands or clothing. Health & Safety data sheets are available on request.



## A Global Dimension

In anticipation of ever-increasing service demands and the need to reduce the costs of downtime, Moorflex has established a network of manufacturing and service centres throughout the world. This network is continually being reviewed and expanded to meet the dynamic expectations of the energy industries.

Quality people, quality service,  
quality products - quality pays.

### MANUFACTURING SITES

United Kingdom  
(Bingley and Tavistock)  
Belgium  
South Africa  
India  
Thailand  
Australia

Abu Dhabi  
Austria  
Bahrain  
Belgium†  
Canada  
Denmark  
Dubai†  
Egypt  
Eire  
Finland

### DISTRIBUTION AND SERVICE FACILITIES

France†	Oman	Sri Lanka
Germany†	Pakistan	Sweden
Greece	Philippines	Switzerland
India†	Poland	Syria
Italy	Portugal	Thailand†
Jordan	Qatar†	Trinidad
Malaysia	Saudi Arabia	UK†
Netherlands	Singapore†	USA
New Zealand	South Africa†	Venezuela
Norway†	Spain†	

† local service facility



Certificate No. FM 01327  
Certificate No. Q 05429



Licensed Under  
API Spec. 6A-0038

### JAMES WALKER MOORFLEX LIMITED

John Escritt Road, Bingley,  
West Yorkshire, BD16 2BS  
England  
Tel: + 44 (0) 1274 562211  
Fax: + 44 (0) 1274 566623  
email: [gaskets@jwmoorflex.co.uk](mailto:gaskets@jwmoorflex.co.uk)  
Web site: [www.jwmoorflex.co.uk](http://www.jwmoorflex.co.uk)

